

# K230 USIP EVB V1.0

## Table of Content

<b>Page 1</b>	<i>Index</i>
<b>Page 2</b>	<i>Block Diagram</i>
<b>Page 3</b>	<i>POWER Diagram</i>
<b>Page 4</b>	<i>K230 USIP PMU SYSC</i>
<b>Page 5</b>	<i>K230 USIP EMMC USB</i>
<b>Page 6</b>	<i>K230 USIP LP3 SIG</i>
<b>Page 7</b>	<i>K230 USIP MIPI TX RX</i>
<b>Page 8</b>	<i>K230 USIP IOMUX</i>
<b>Page 9</b>	<i>K230 USIP POWER1</i>
<b>Page 10</b>	<i>K230 USIP POWER2</i>
<b>Page 11</b>	<i>K230 USIP GND</i>
<b>Page 12</b>	<i>K230 USIP ADC AUDIO</i>
<b>Page 13</b>	<i>LP3 POWER</i>
<b>Page 14</b>	<i>POWER FOR LP3</i>
<b>Page 15</b>	<i>POWER FOR CORE CPU</i>
<b>Page 16</b>	<i>POWER FOR IO</i>
<b>Page 17</b>	<i>POWER FOR OTHER</i>
<b>Page 18</b>	<i>POWER ON-OFF SET</i>
<b>Page 19</b>	<i>POWER FOR KPU</i>
<b>Page 20</b>	<i>TF CARD</i>
<b>Page 21</b>	<i>DEBUG UART</i>
<b>Page 22</b>	<i>EXT CON</i>
<b>Page 23</b>	<i>POWER IN DET ADJ</i>

## Revision History

<b>Rev.code</b>	<b>Data</b>	<b>By</b>	<b>Description</b>
V1.0	20221216	ZYF	Initial Version
V1.1	20230313	ZYF	

<Core Design>



**Title : K230 USIP EVB**

**Designer:ZYF**    **Revision: V1.1**    **Size: A4**

**Date: Monday, June 05, 2023**    **Sheet 1 of 23**

# K230 USIP EVB V1.0

## ---System Architecture Block---

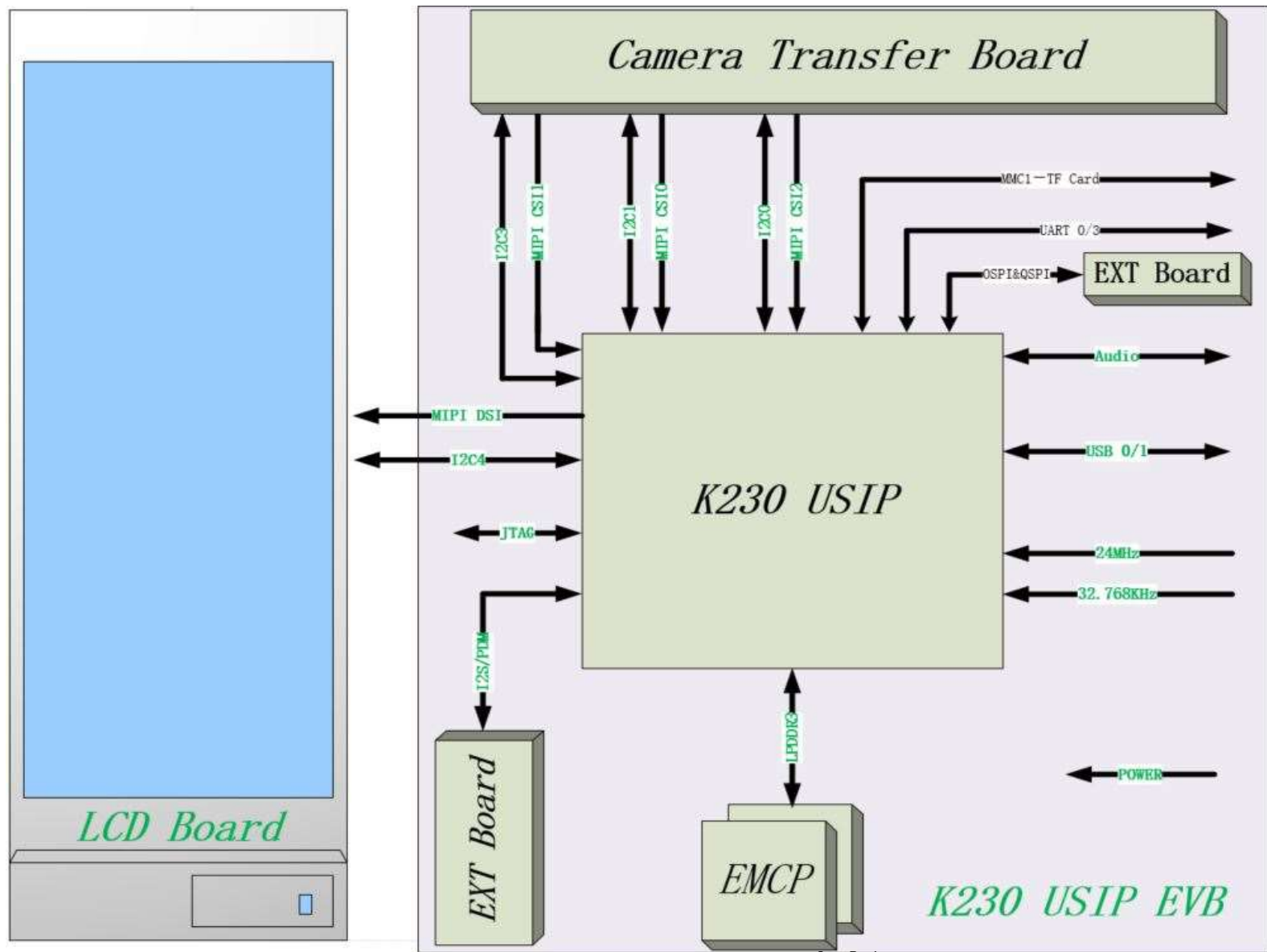

<Core Design>



Title: K230 USIP EVB

Designer: ZYF    Revision: V1.1    Size: A4

Date: Monday, June 05, 2023    Sheet 2 of 23

# K230 USIP EVB V1.0

## ---POWER Architecture Block---

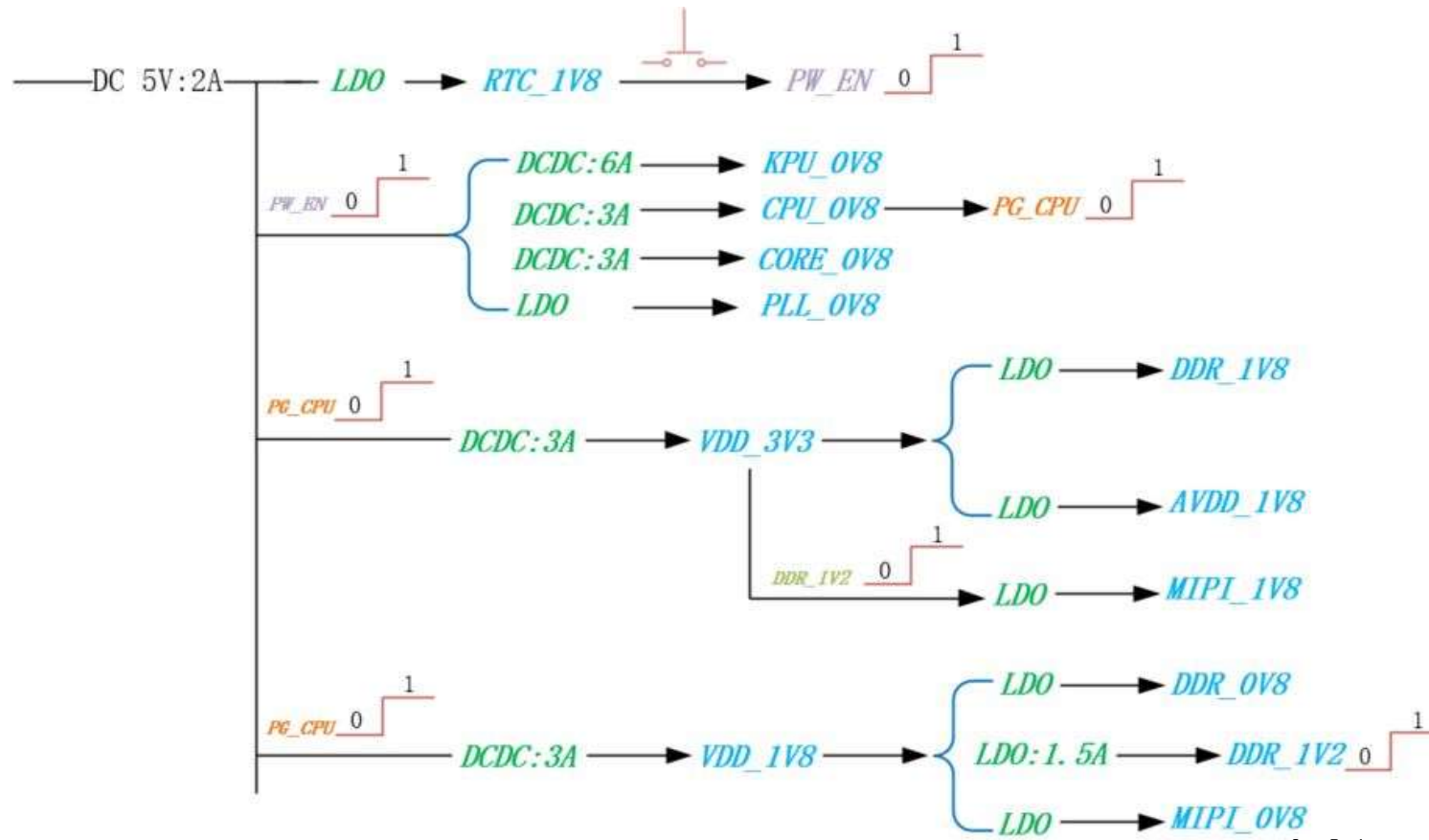

<Core Design>



Title : K230 USIP EVB

Designer:ZYF

Revision: V1.1

Size: A4

Date: Monday, June 05, 2023

Sheet 3 of 23

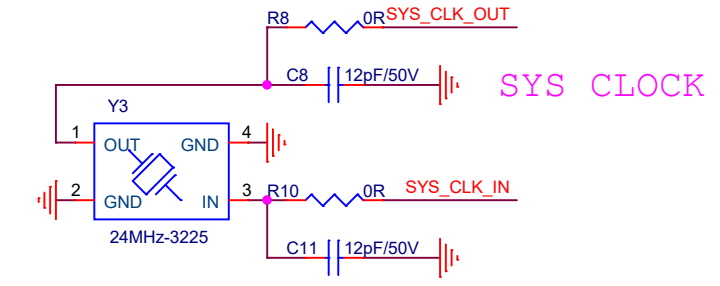
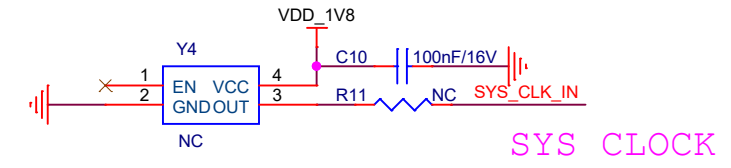
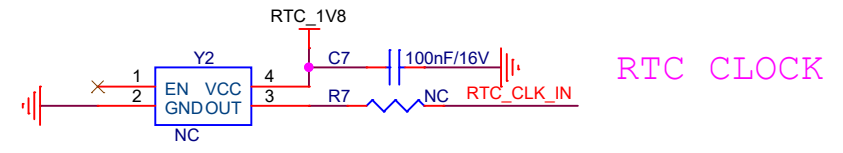
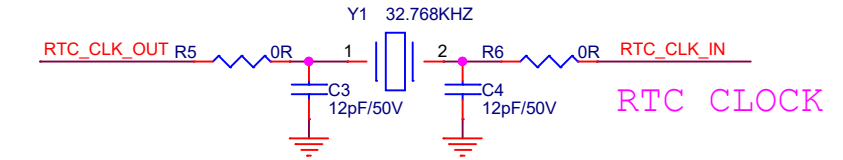
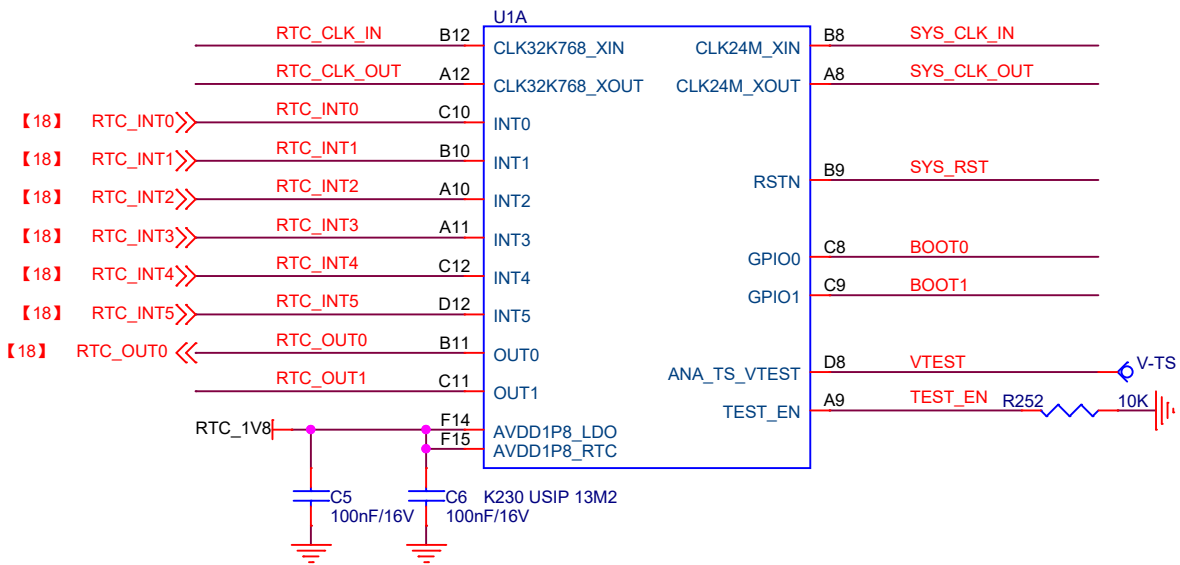

**SYS BOOT SW**

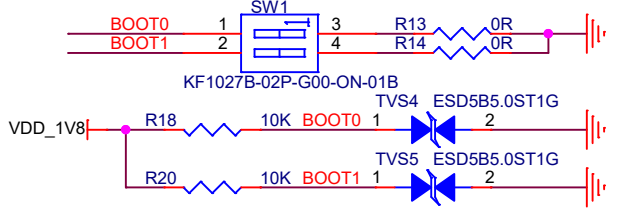

	<b>BOOT0</b>		
<b>BOOT1</b>	<b>0</b>	<b>1</b>	
<b>0</b>	<b>NOR FLASH</b>	<b>NAND FLASH</b>	
<b>1</b>	<b>EMMC</b>	<b>TF CARD</b>	

**SYS RST**

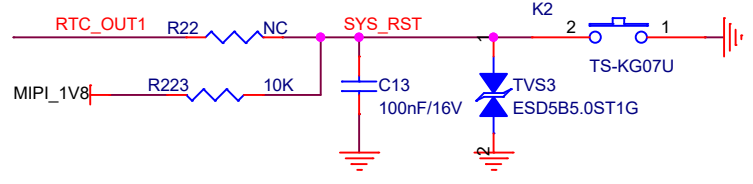

**SYS RST KEY**

<Core Design>



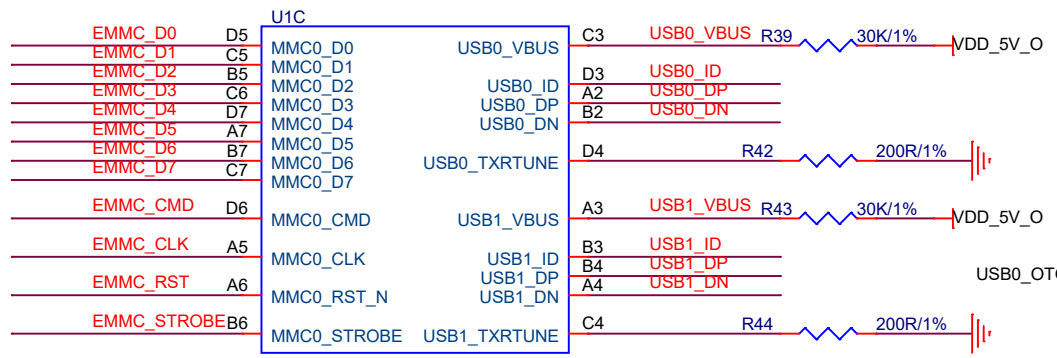

K230 USIP 13M2

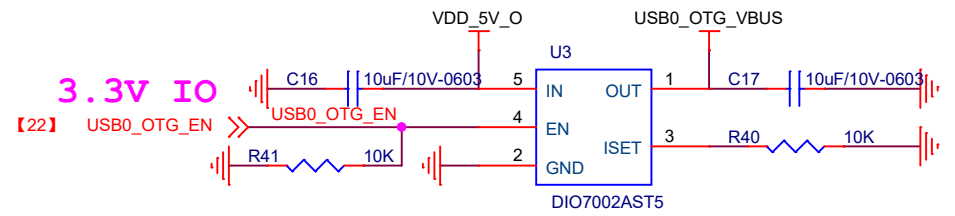

ON	VOUT
L	XX
H	VIN

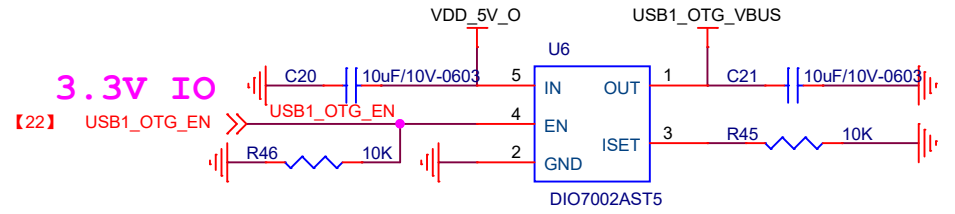
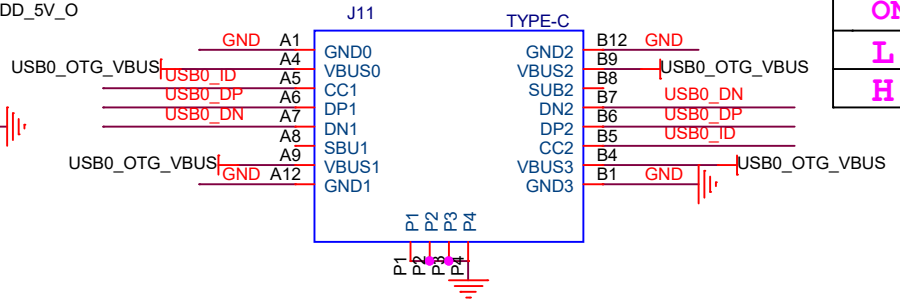

ON	VOUT
L	XX
H	VIN

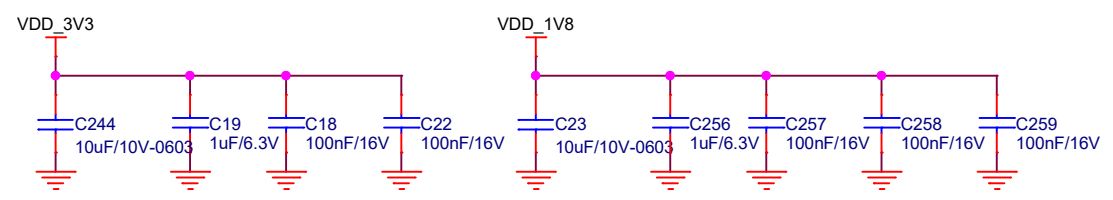
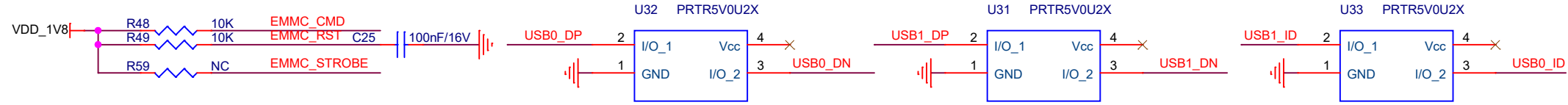
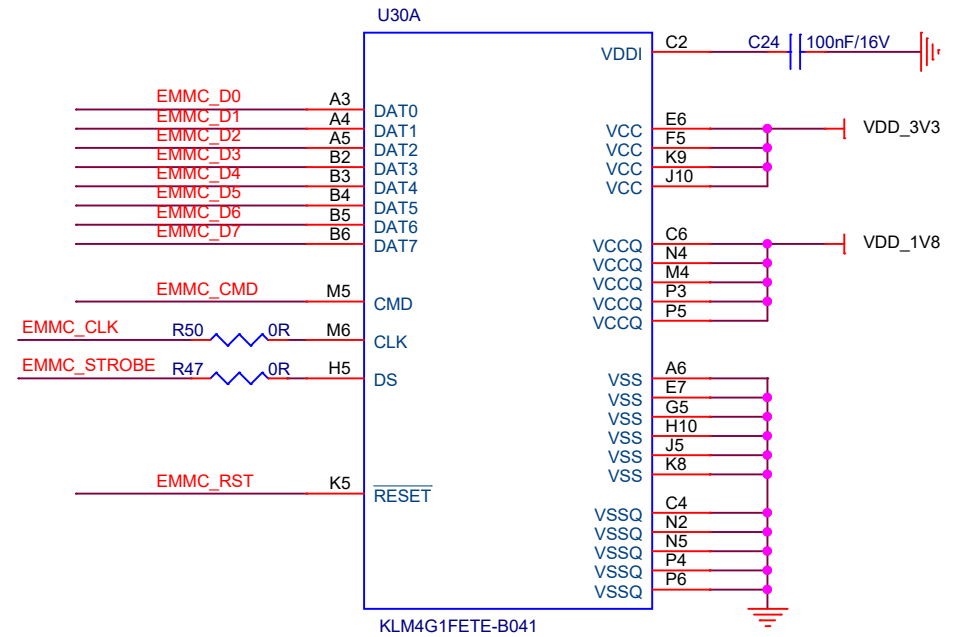
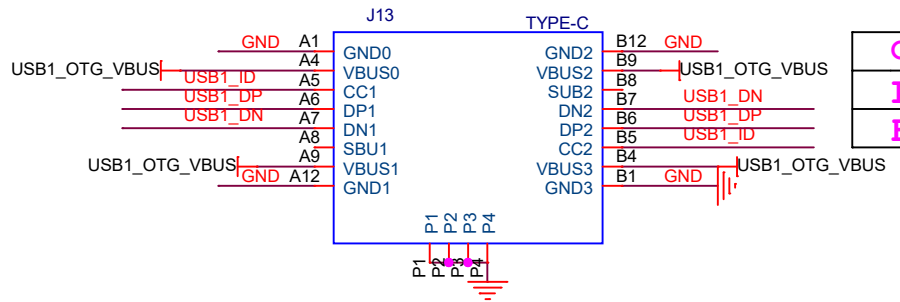

<Core Design>





K230 USIP 13M2

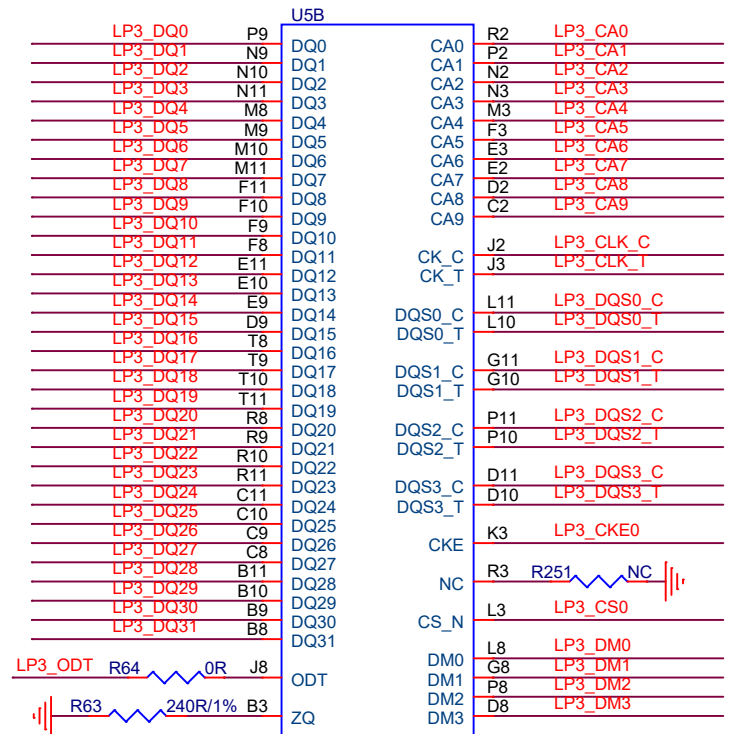
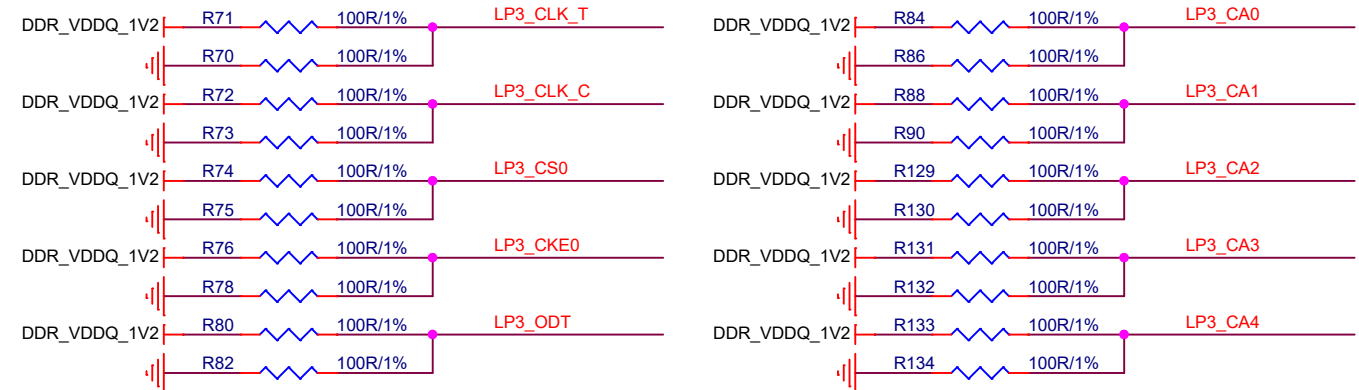

NT6CL128M32DM-H0

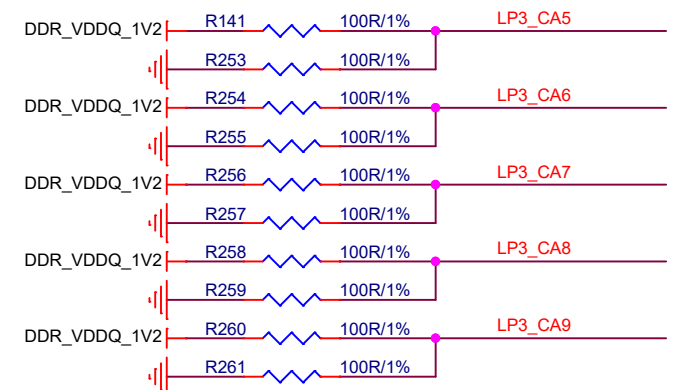

<Core Design>



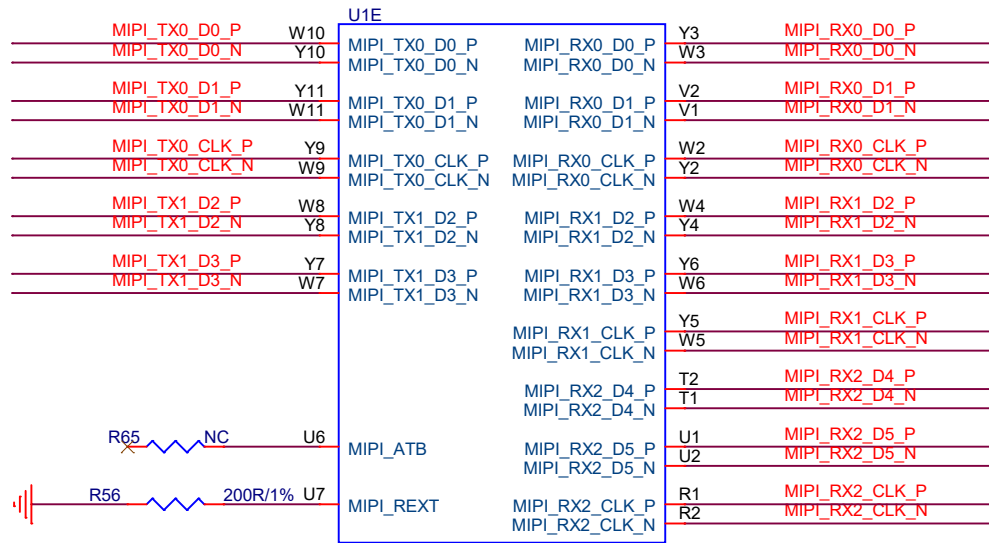

K230 USIP 13M2

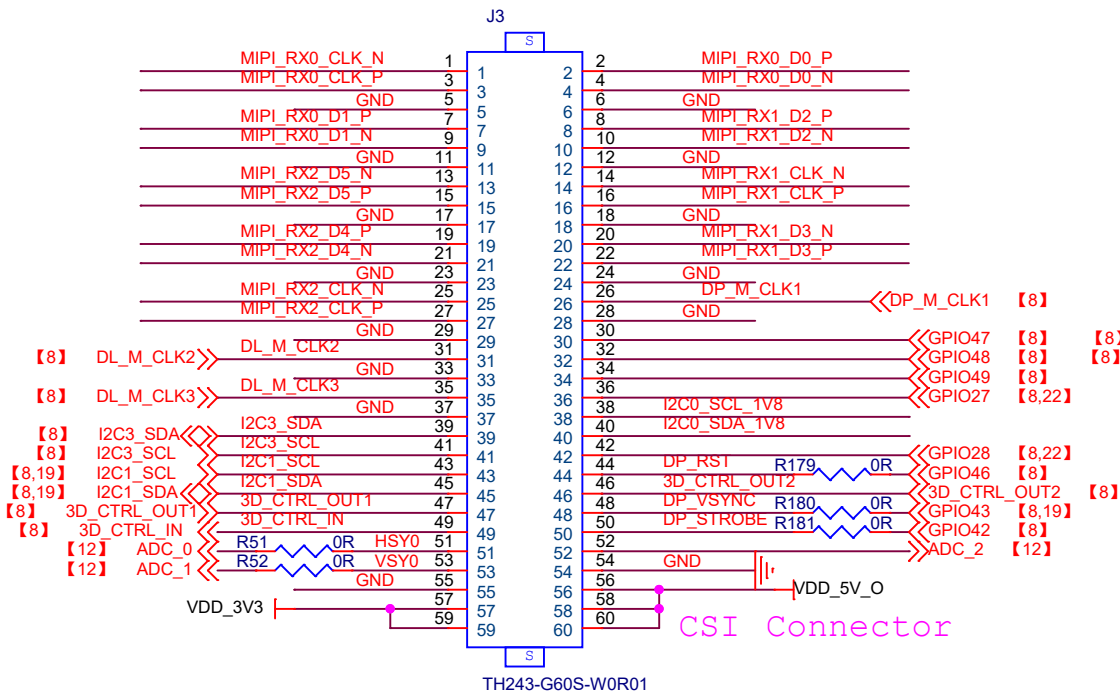

TH243-G60S-W0R01

GPIO 42/43/46 FOR DP & PW\_PWM  
 GPIO 27/28/47/48/49 FOR DL  
 GPIO 60/61 AS I2C0&HS1/VS1

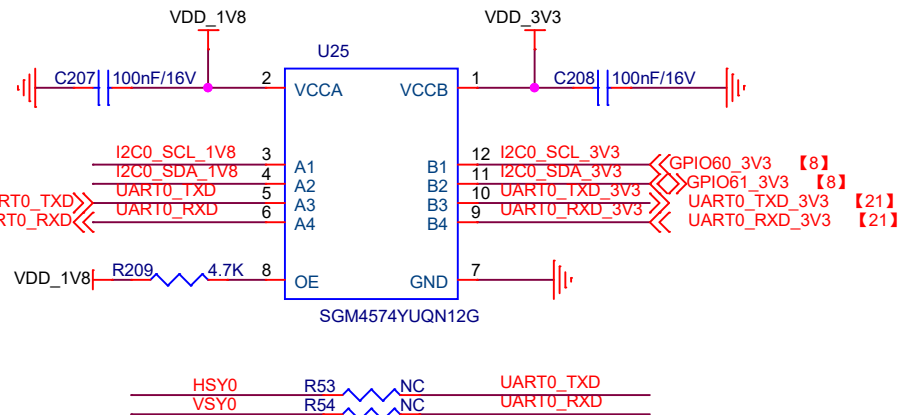
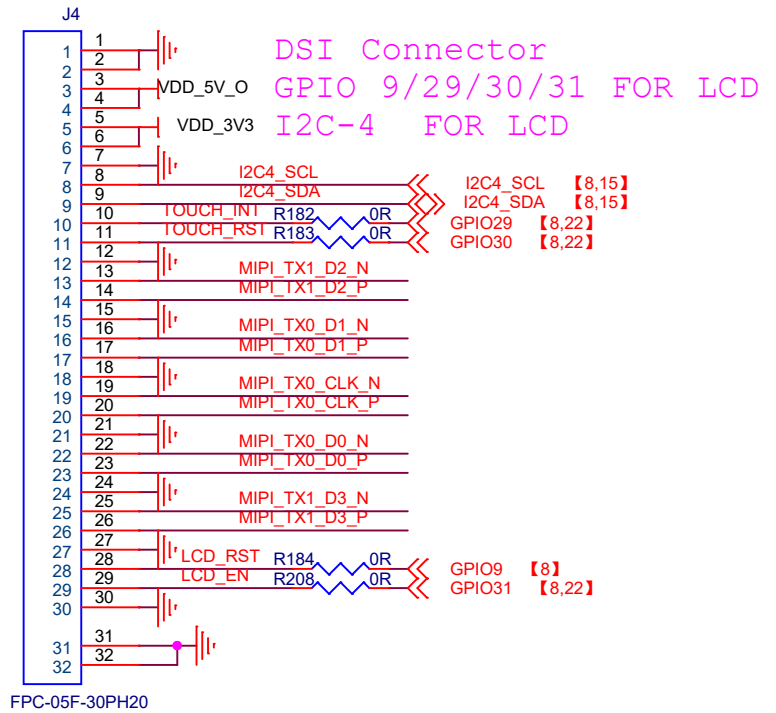
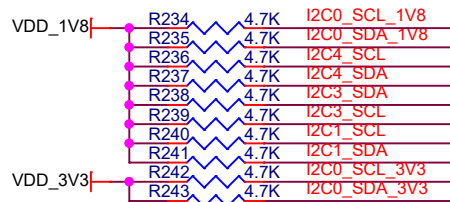

For Two Slave Sensor Test

<Core Design>



Title: K230 USIP EVB

Designer: ZYF	Revision: V1.1	Size: A4
---------------	----------------	----------

Date: Monday, June 05, 2023	Sheet 7 of 23
-----------------------------	---------------



JTAG  
I2C4  
LCD  
STROBE  
MCLK1

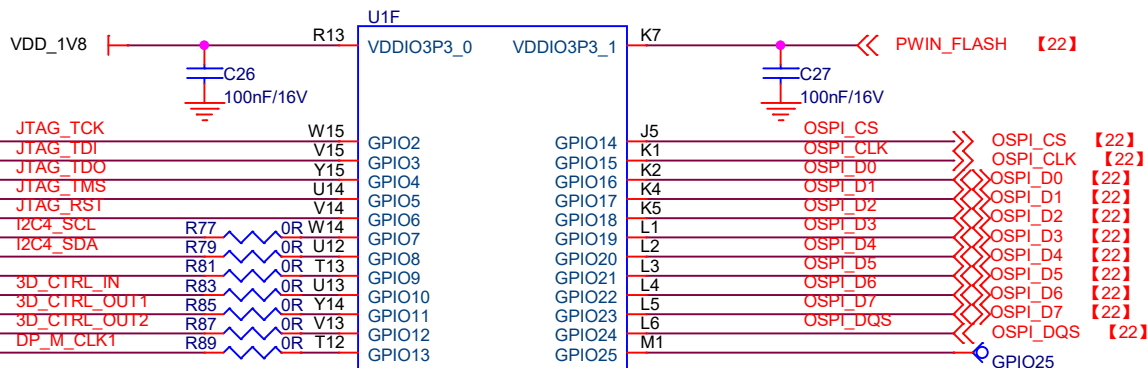

GPIO 25 FOR TEST

I2S&PDM

GPIO26  
GPIO27  
GPIO28  
GPIO29  
GPIO30  
GPIO31  
GPIO32  
GPIO33  
GPIO34  
GPIO35  
GPIO36  
GPIO37

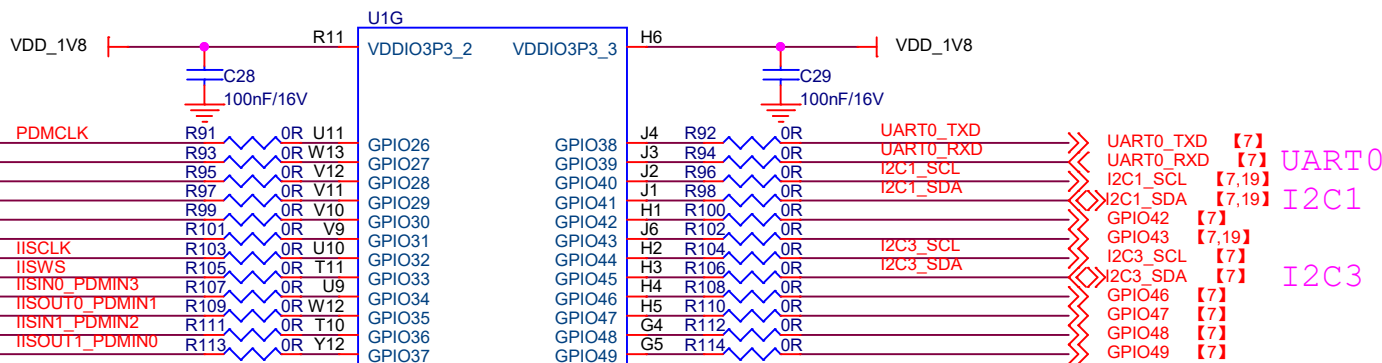

UART3  
TF CARD  
I2C0

UART3\_TXD  
UART3\_RXD  
GPIO52  
GPIO53  
MMC1\_CMD  
MMC1\_CLK  
MMC1\_D0  
MMC1\_D1  
MMC1\_D2  
MMC1\_D3  
GPIO060\_3V3  
GPIO061\_3V3

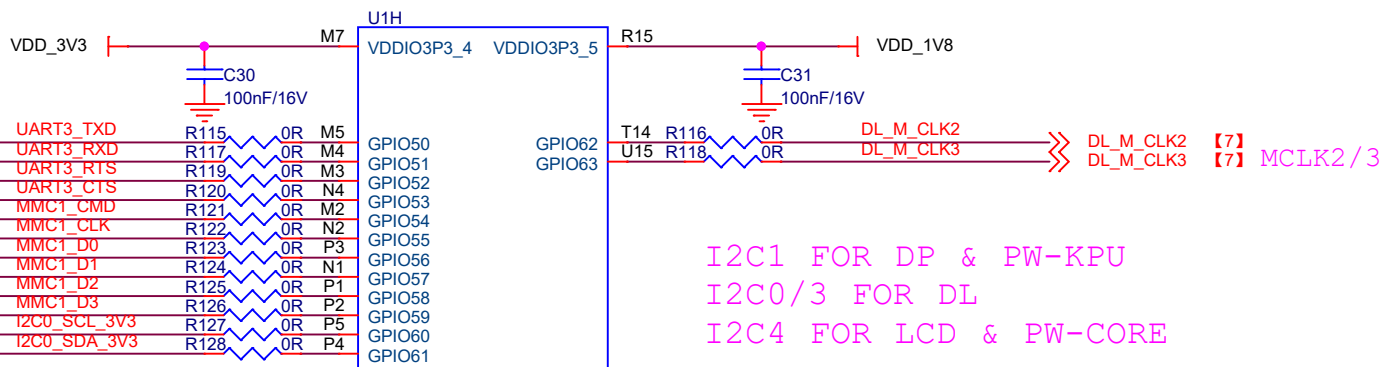

I2C1 FOR DP & PW-KPU  
I2C0/3 FOR DL  
I2C4 FOR LCD & PW-CORE

GPIO 42/43/46 FOR DP & PW\_PWM  
GPIO 9/29/30/31 FOR LCD  
GPIO 27/28/47/48/49 FOR DL  
GPIO 26/32/33/34/35 FOR I2S&PDM

GPIO 52 FOR USB-OTG & UART3-RTS  
GPIO 53 FOR TF-DET & UART3-CTS  
GPIO 36/37 TBD  
GPIO 25 NOT USED

<Core Design>



Title: K230 USIP EVB

Designer: ZYF      Revision: V1.1      Size: A4

Date: Monday, June 05, 2023      Sheet 8 of 23



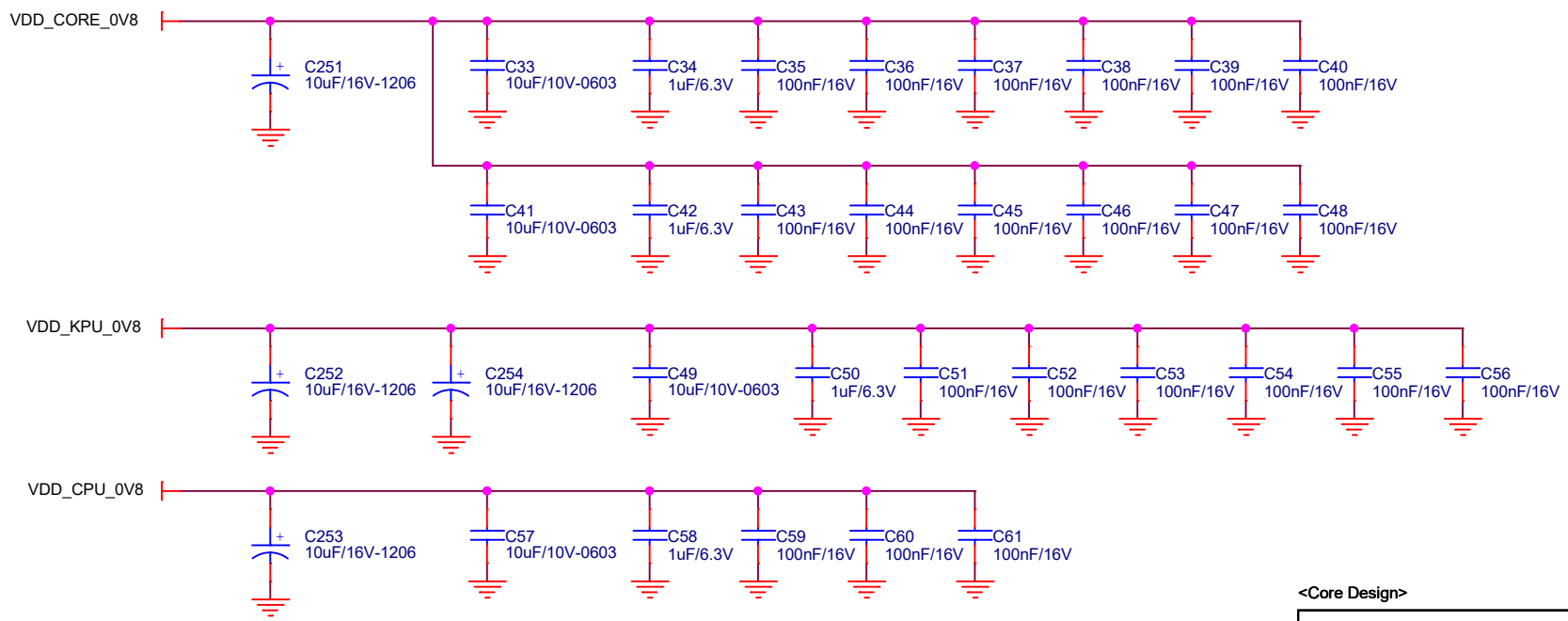
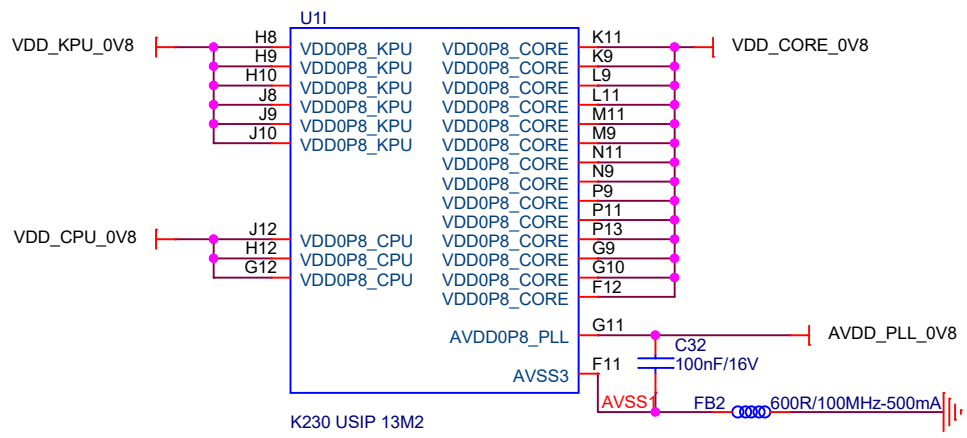

<Core Design>



Title: <b>K230 USIP EVB</b>		
Designer: <b>ZYF</b>	Revision: <b>V1.1</b>	Size: <b>A4</b>
Date: <b>Monday, June 05, 2023</b>	Sheet <b>9</b> of <b>23</b>	

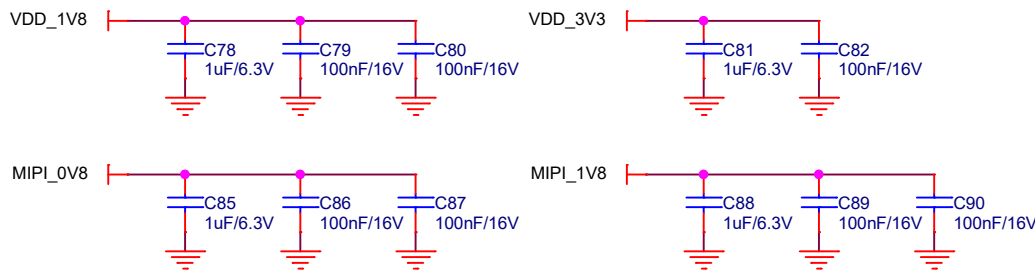
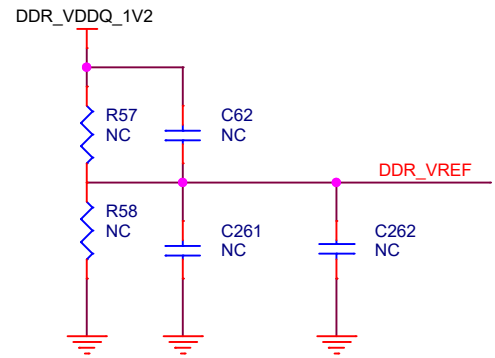
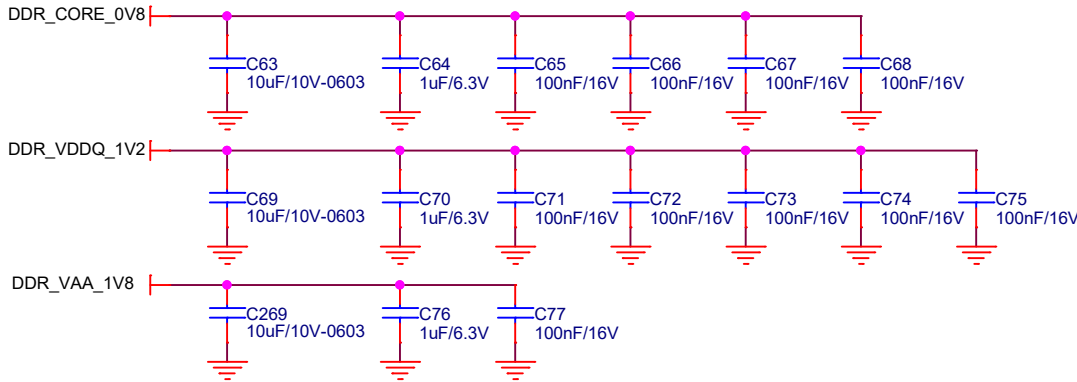
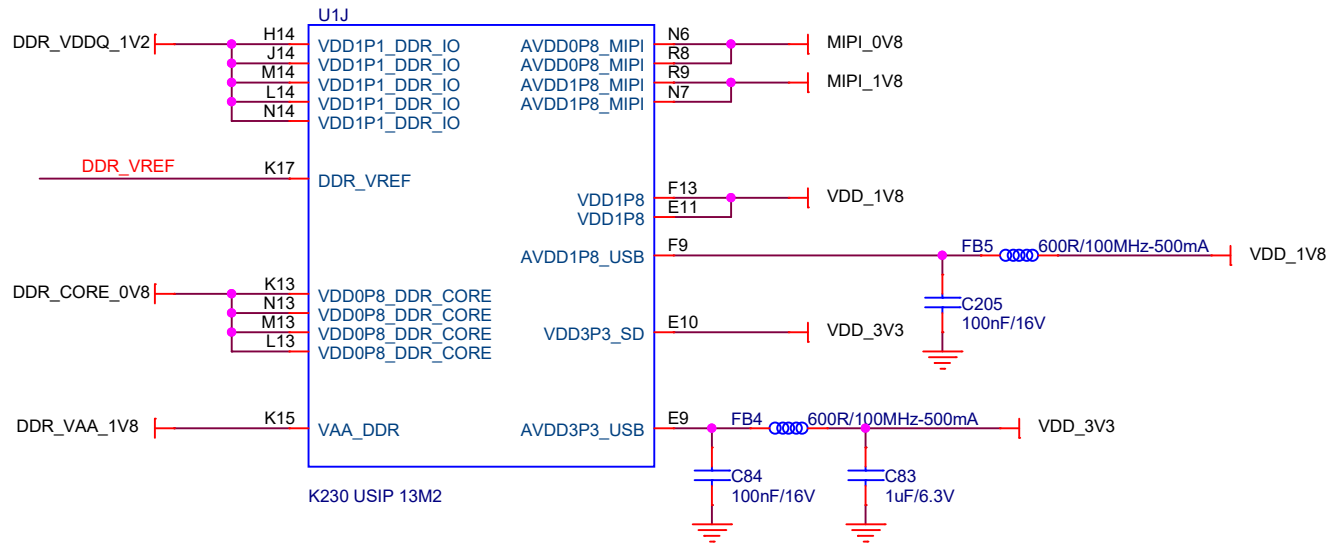

<Core Design>



Title: <b>K230 USIP EVB</b>		
Designer: <b>ZYF</b>	Revision: <b>V1.1</b>	Size: <b>A4</b>
Date: <b>Monday, June 05, 2023</b>	Sheet <b>10</b> of <b>23</b>	



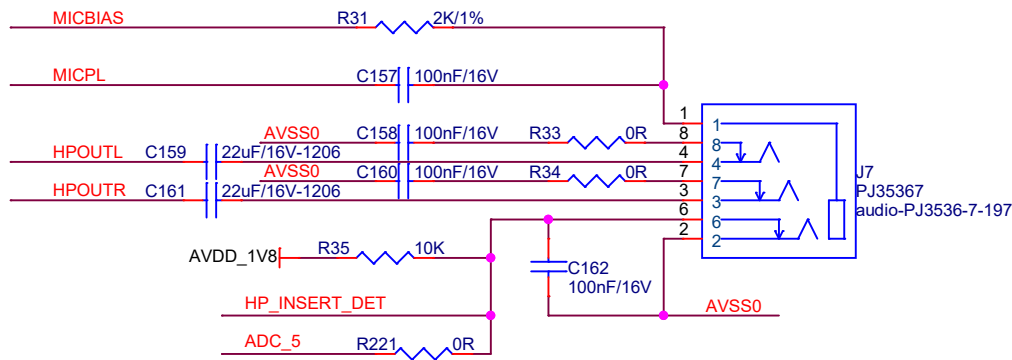
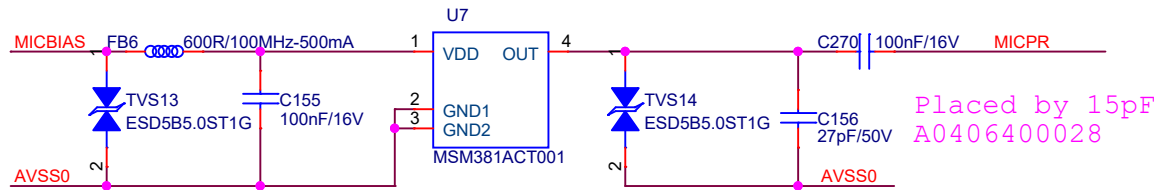
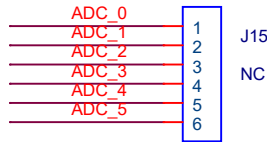
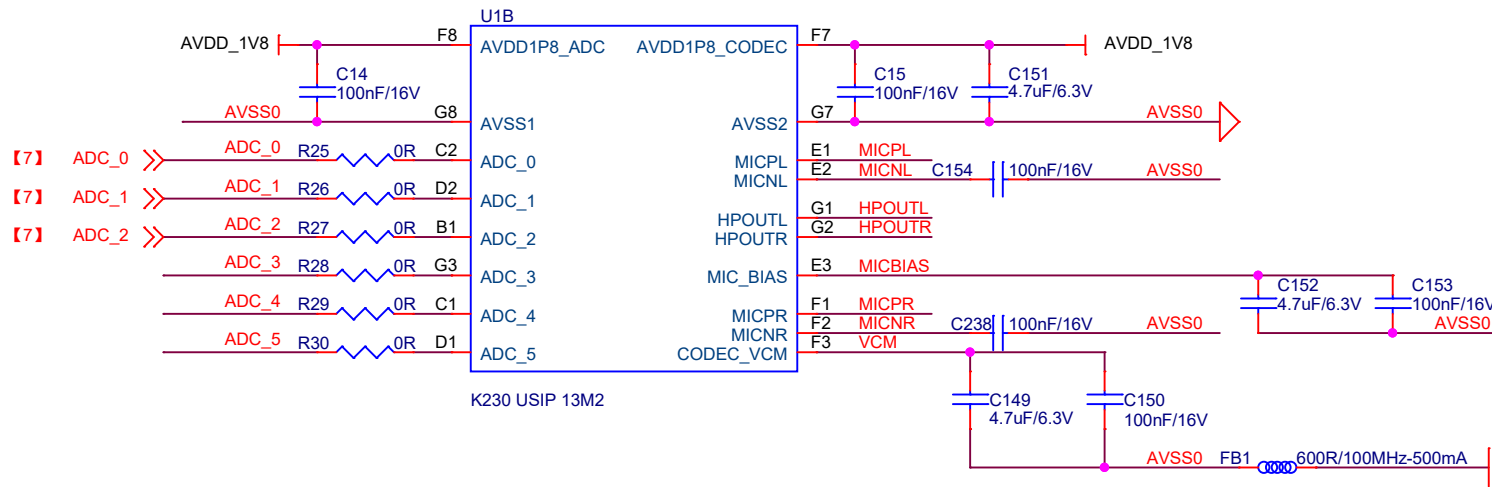

<Core Design>



Title: K230 USIP EVB

Designer: ZYF	Revision: V1.1	Size: A4
---------------	----------------	----------

Date: Monday, June 05, 2023	Sheet 12 of 23
-----------------------------	----------------

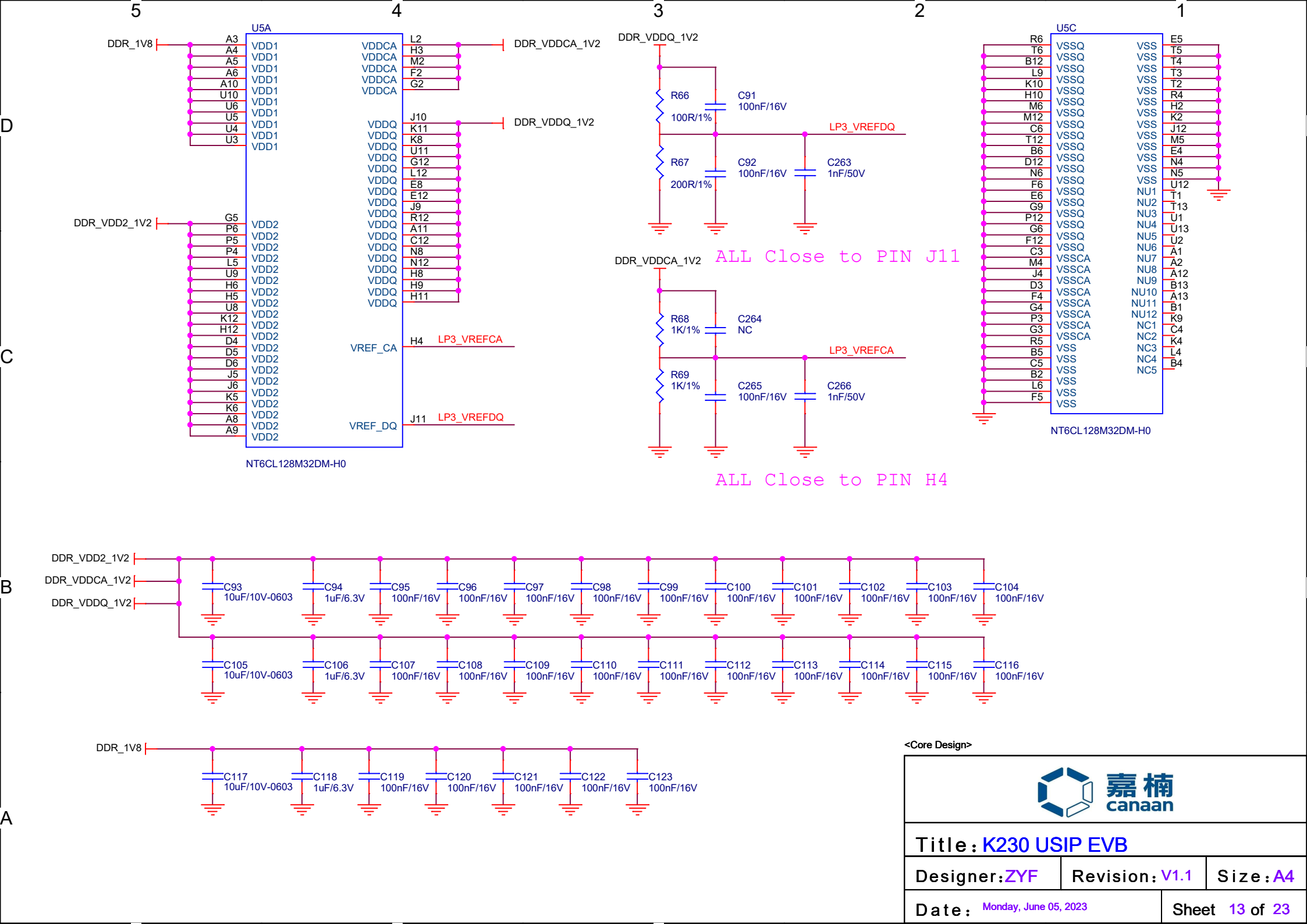

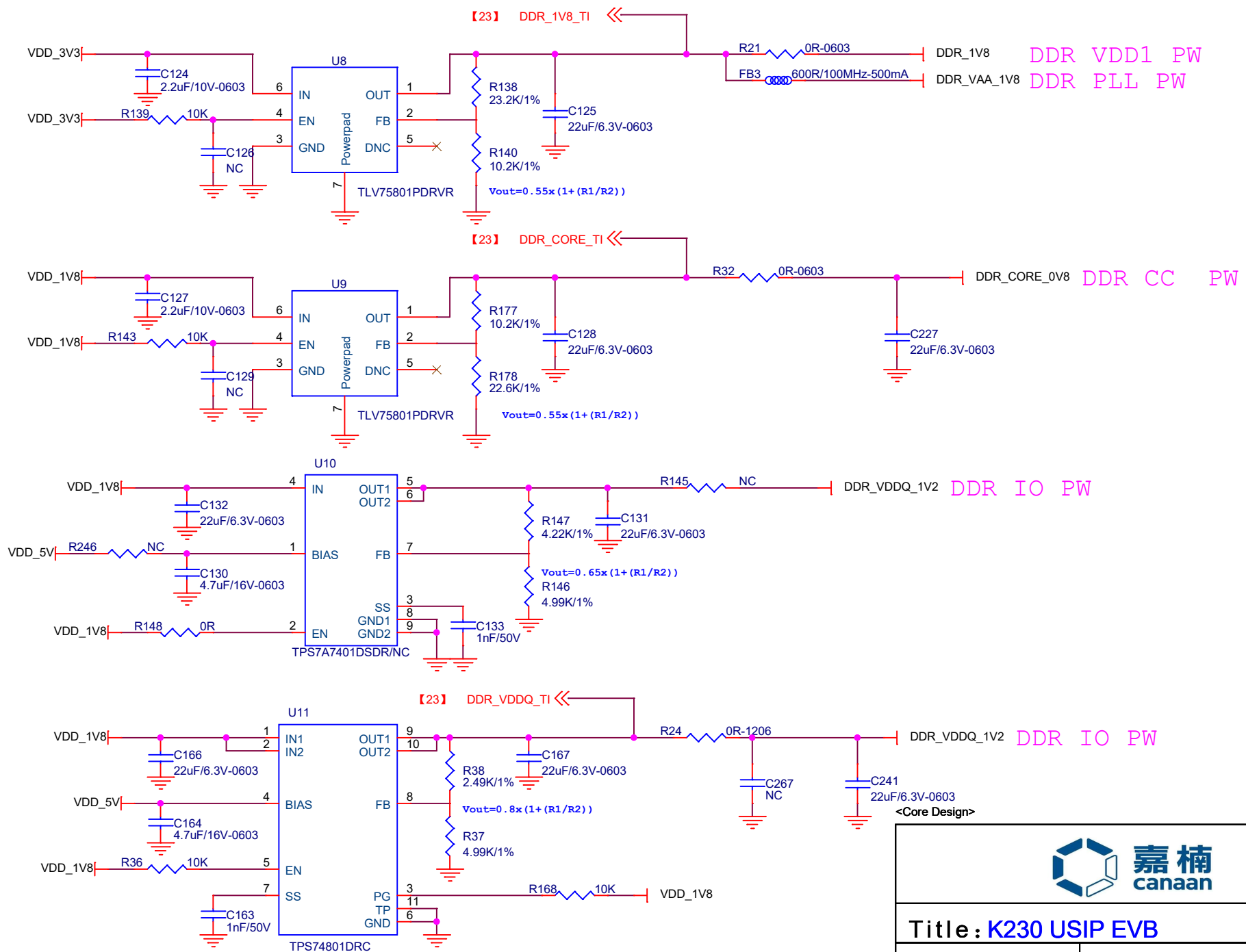

Title: <b>K230 USIP EVB</b>		
Designer: <b>ZYF</b>	Revision: <b>V1.1</b>	Size: <b>A4</b>
Date: <b>Monday, June 05, 2023</b>	Sheet <b>14</b> of <b>23</b>	

D

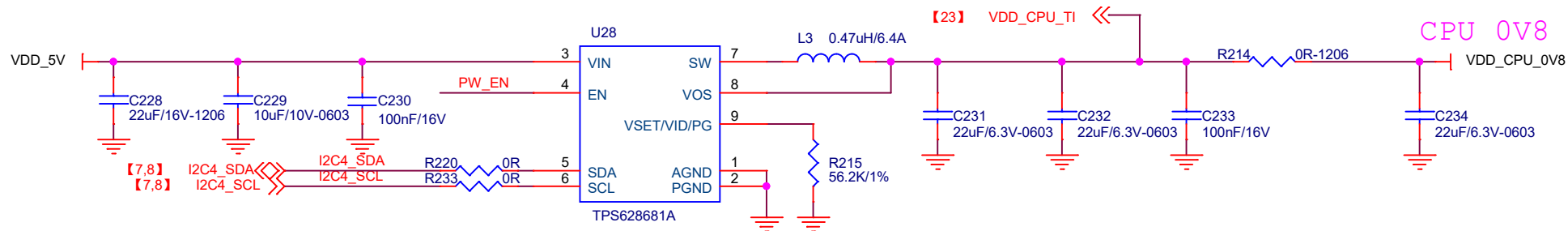

C

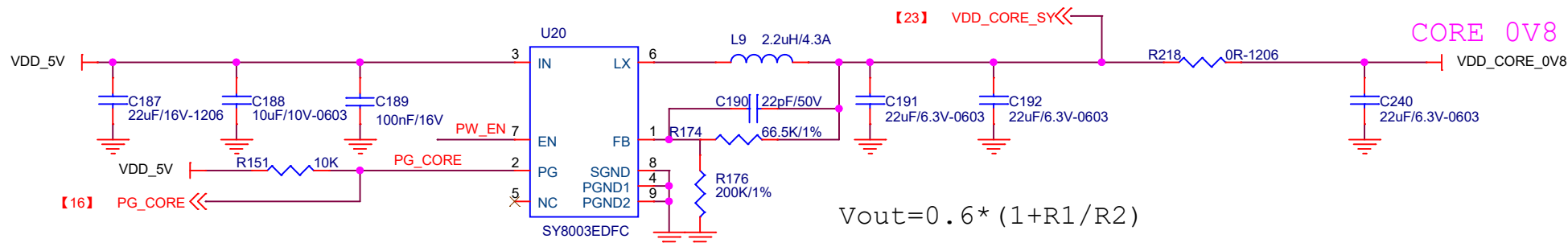

B

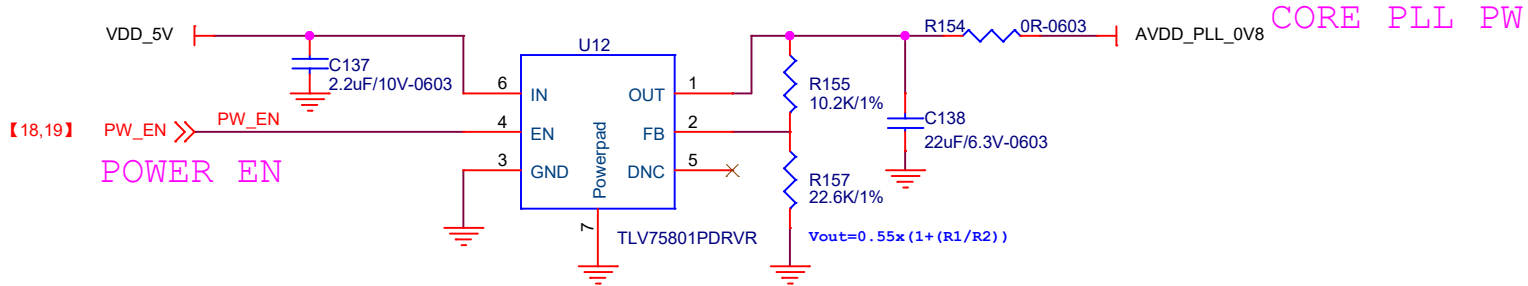

A

<Core Design>



Title: K230 USIP EVB		
Designer: ZYF	Revision: V1.1	Size: A4
Date: Monday, June 05, 2023	Sheet 15 of 23	



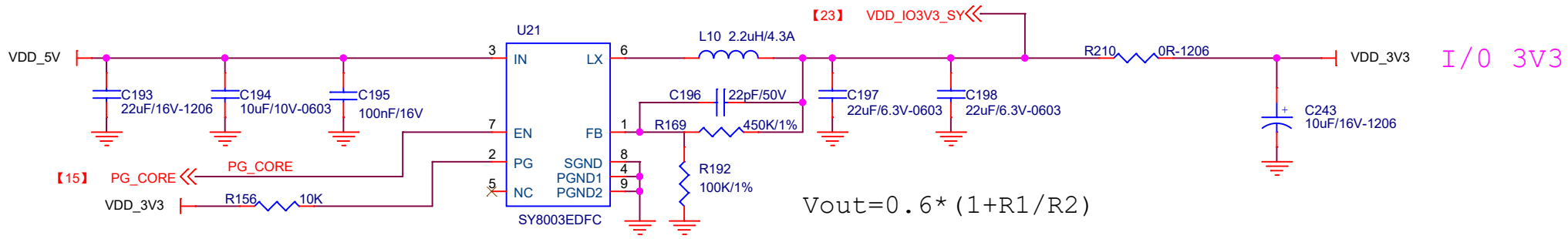
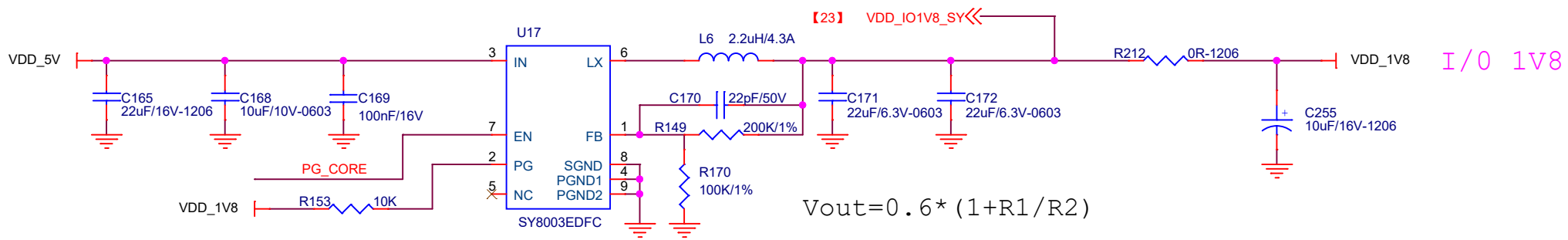

<Core Design>



Title: <b>K230 USIP EVB</b>		
Designer: <b>ZYF</b>	Revision: <b>V1.1</b>	Size: <b>A4</b>
Date: <b>Monday, June 05, 2023</b>	Sheet <b>16</b> of <b>23</b>	

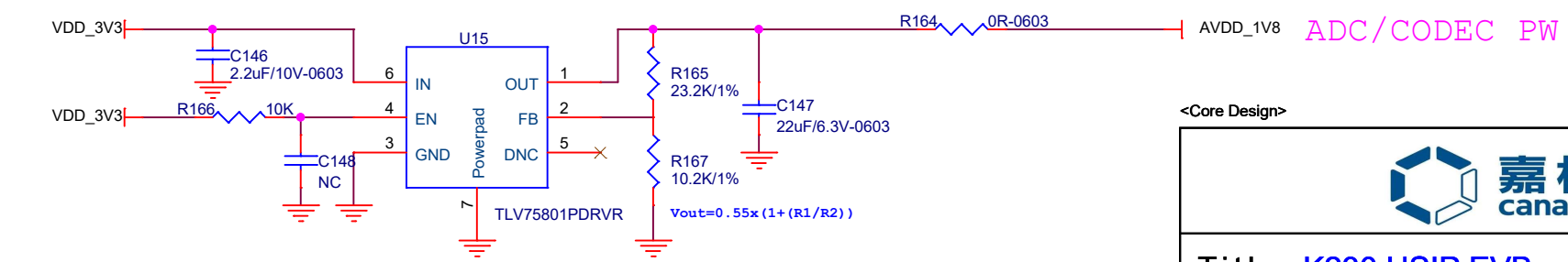
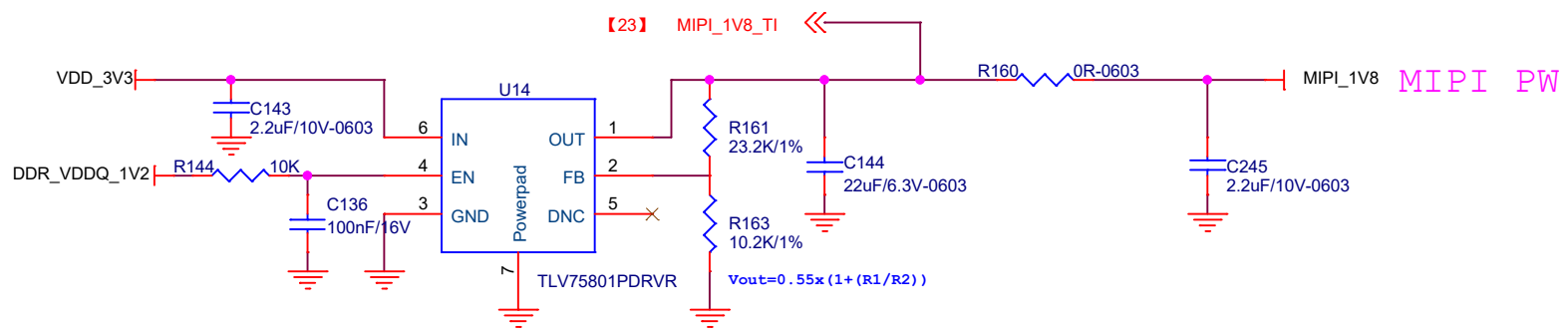
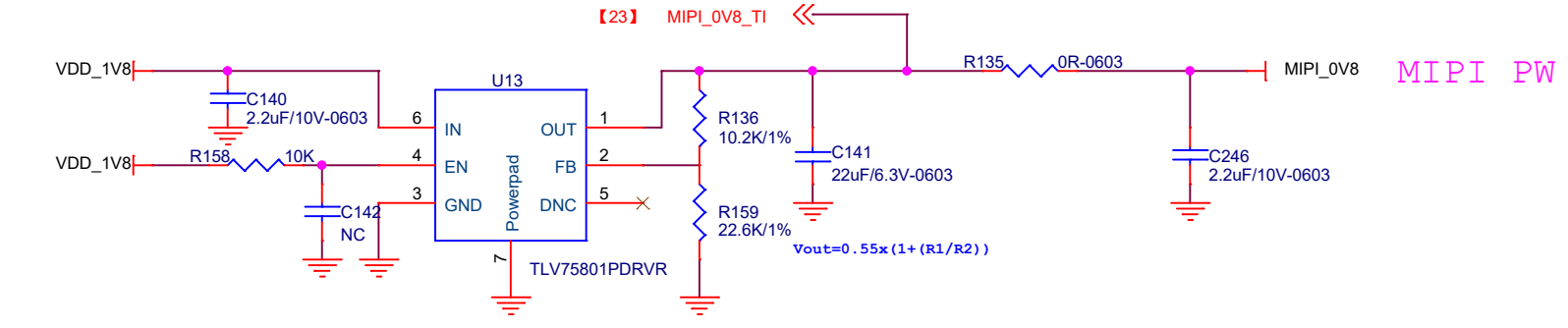
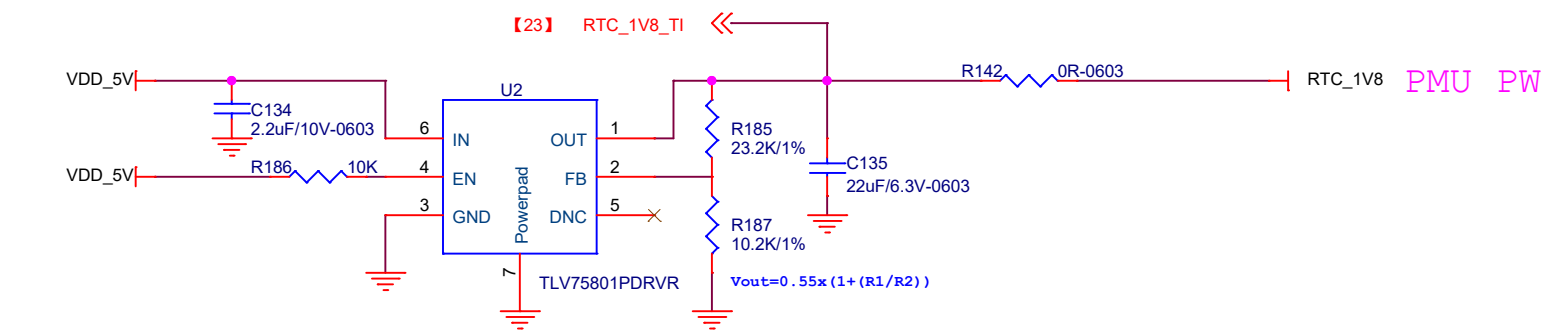

<Core Design>



Title: K230 USIP EVB		
Designer: ZYF	Revision: V1.1	Size: A4
Date: Monday, June 05, 2023	Sheet 17 of 23	

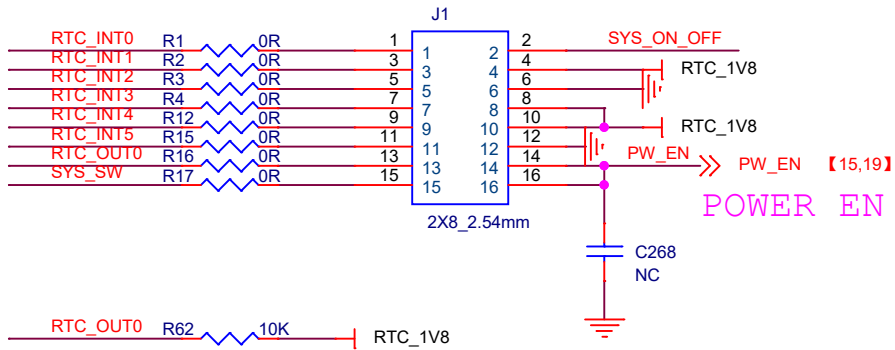

POWER BY BUTTON:  
 1. JUMPER J1 1/2  
 2. JUMPER J1 13/14

POWER ON/OFF BY SWITCH:  
 1. JUMPER J1 15/16

POWER ON BY INT4 HIGH LEVEL:  
 1. JUMPER J1 9/10  
 2. JUMPER J1 13/14

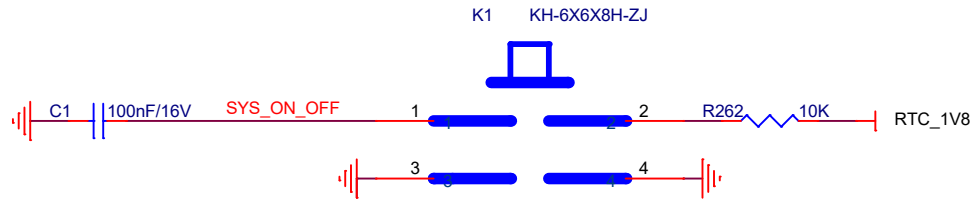
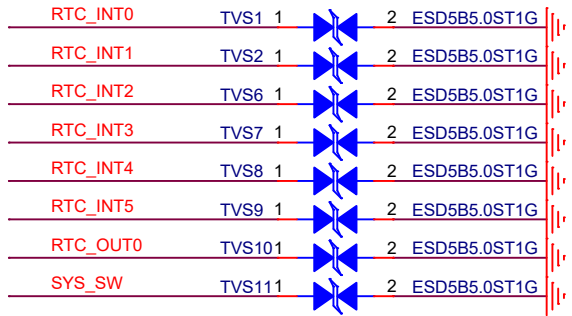

1. POWER ON BUTTON

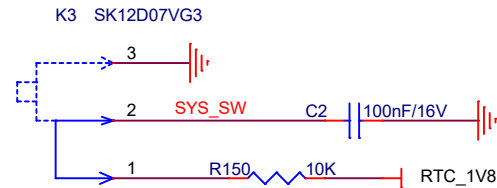

2. POWER ON/OFF SW

- 【4】 RTC\_INT0 >> RTC\_INT0
- 【4】 RTC\_INT1 >> RTC\_INT1
- 【4】 RTC\_INT2 >> RTC\_INT2
- 【4】 RTC\_INT3 >> RTC\_INT3
- 【4】 RTC\_INT4 >> RTC\_INT4
- 【4】 RTC\_INT5 >> RTC\_INT5
- 【4】 RTC\_OUT0 << RTC\_OUT0

<Core Design>



Title: K230 USIP EVB

Designer: ZYF      Revision: V1.1      Size: A4

Date: Monday, June 05, 2023      Sheet 18 of 23

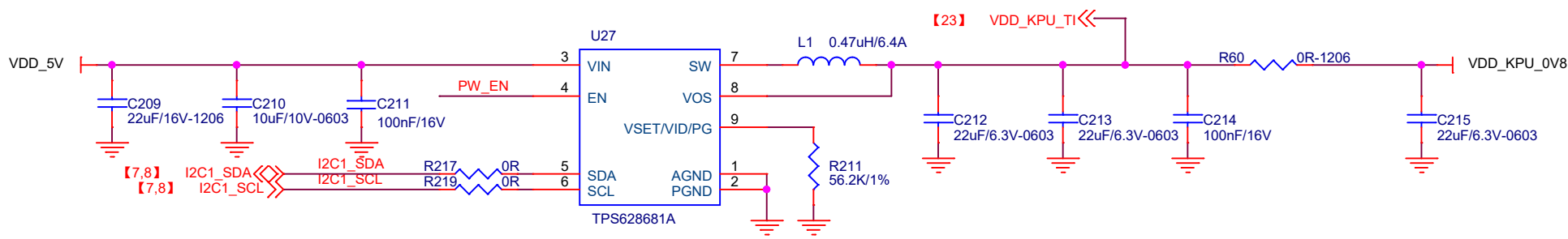

KPU OV8

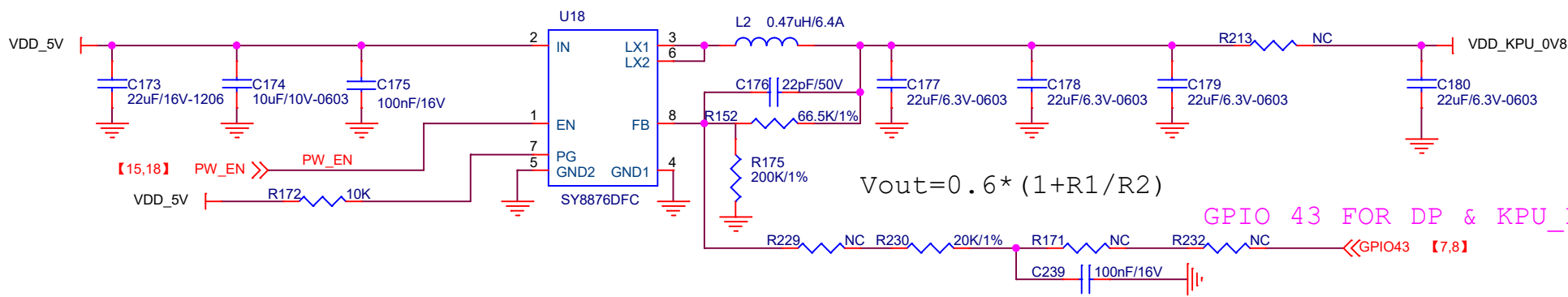

GPIO 43 FOR DP & KPU\_PWM

<Core Design>



Title: K230 USIP EVB		
Designer: ZYF	Revision: V1.1	Size: A4
Date: Monday, June 05, 2023	Sheet 19 of 23	

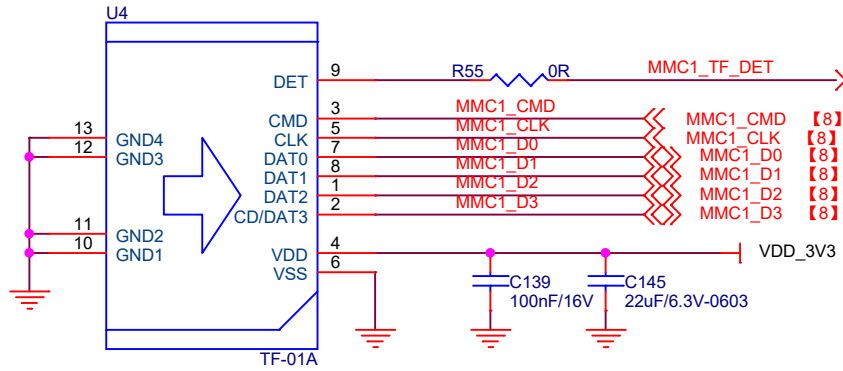

TF CARD

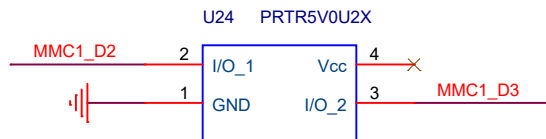
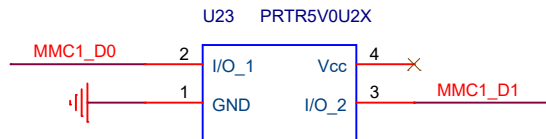
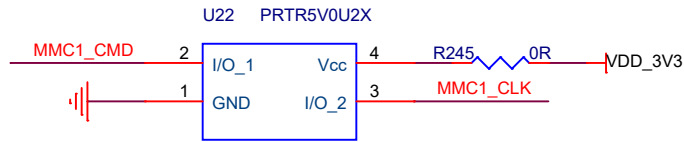
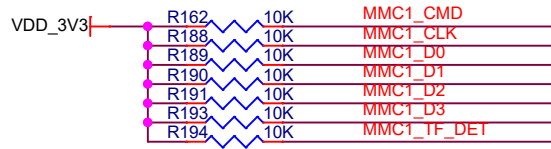

<Core Design>



Title: K230 USIP EVB

Designer: ZYF

Revision: V1.1

Size: A4

Date: Monday, June 05, 2023

Sheet 20 of 23

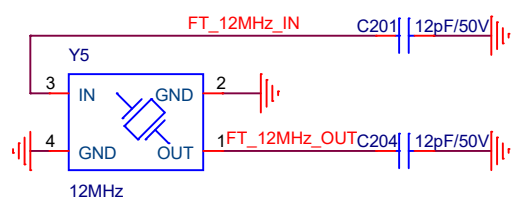
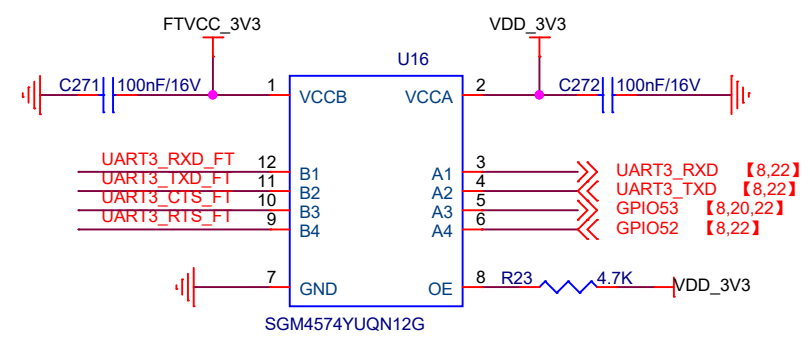
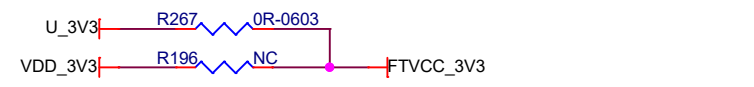
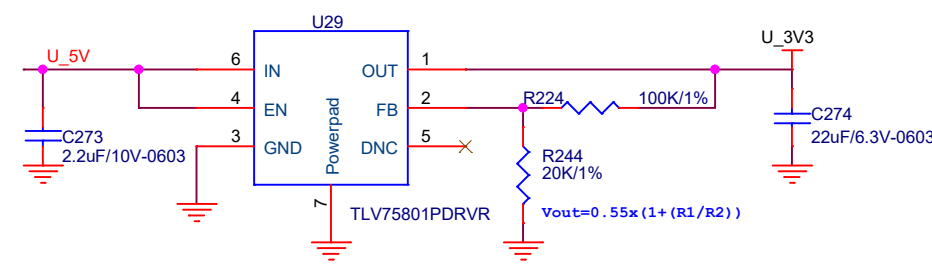
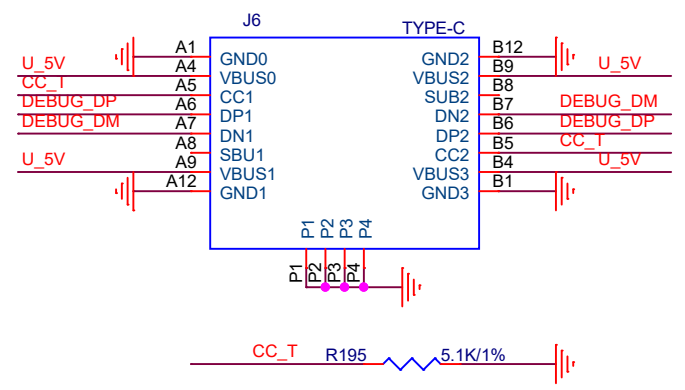
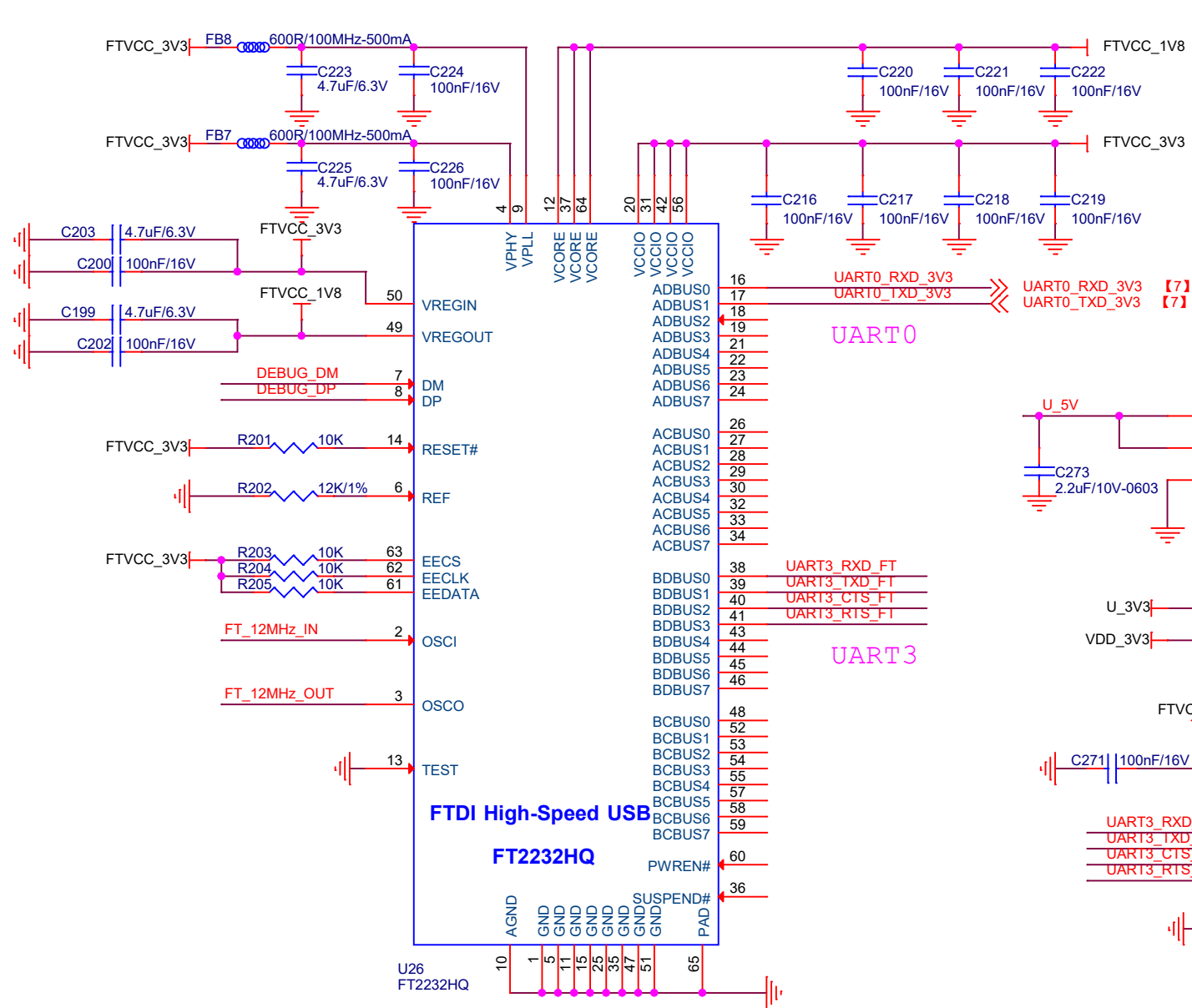

<Core Design>



Title: <b>K230 USIP EVB</b>		
Designer: <b>ZYF</b>	Revision: <b>V1.1</b>	Size: <b>A4</b>
Date: <b>Monday, June 05, 2023</b>		Sheet <b>21</b> of <b>23</b>

### SPI&OSPI EXT

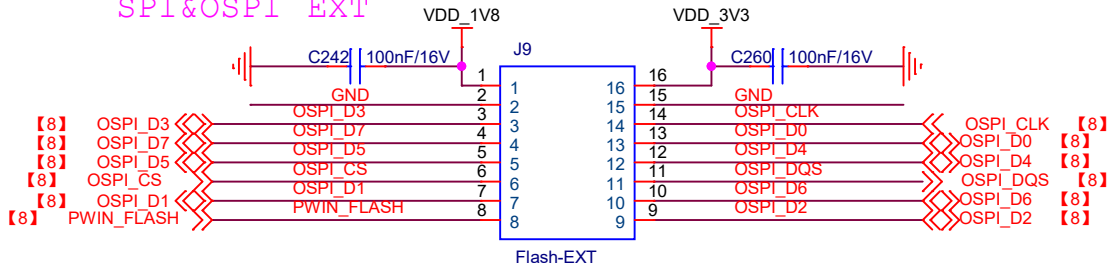

Connect PWIN\_FLASH ON EXT Board

### JTAG

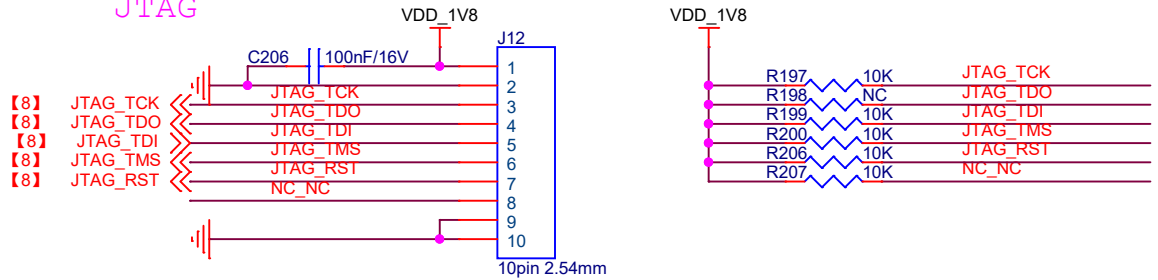

### I2S&PDM EXT

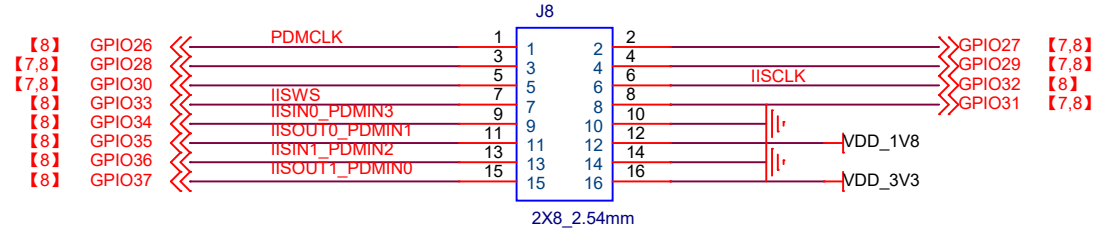

GPIO 26/32/33/34/35 FOR I2S&PDM

GPIO 27/28/29/30/31 NOT USED ON EXT Board

GPIO 36/37 TBD

GPIO 36/37 UART4 TX/RX

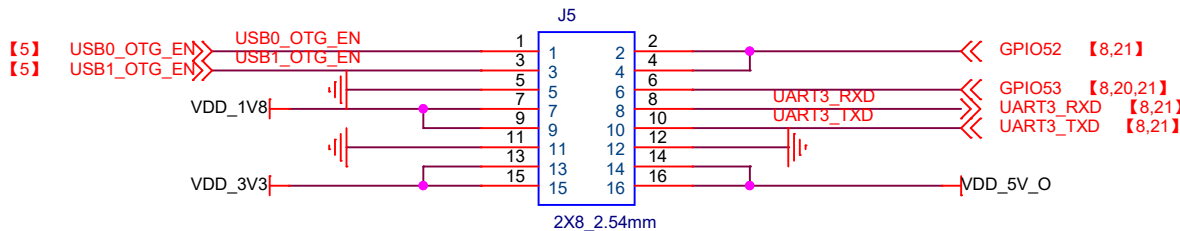

GPIO 52 FOR USB-OTG & UART3-RTS

GPIO 53 FOR TF-DET & UART3-CTS & WIFI

<Core Design>



Title: <b>K230 USIP EVB</b>		
Designer: <b>ZYF</b>	Revision: <b>V1.1</b>	Size: <b>A4</b>
Date: <b>Monday, June 05, 2023</b>	Sheet <b>22</b> of <b>23</b>	



### POWER IN DCDC:5V 2A

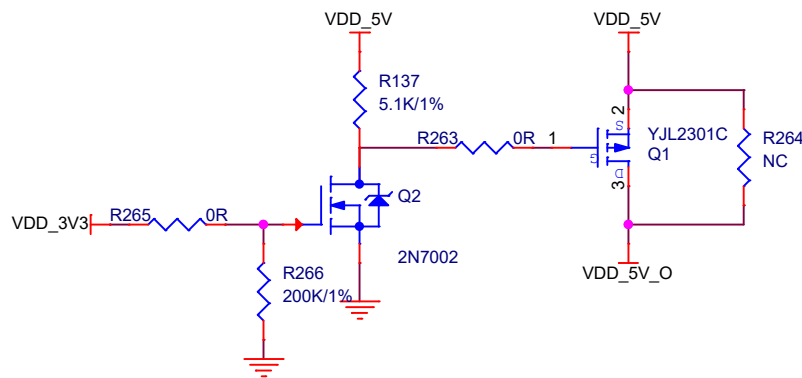
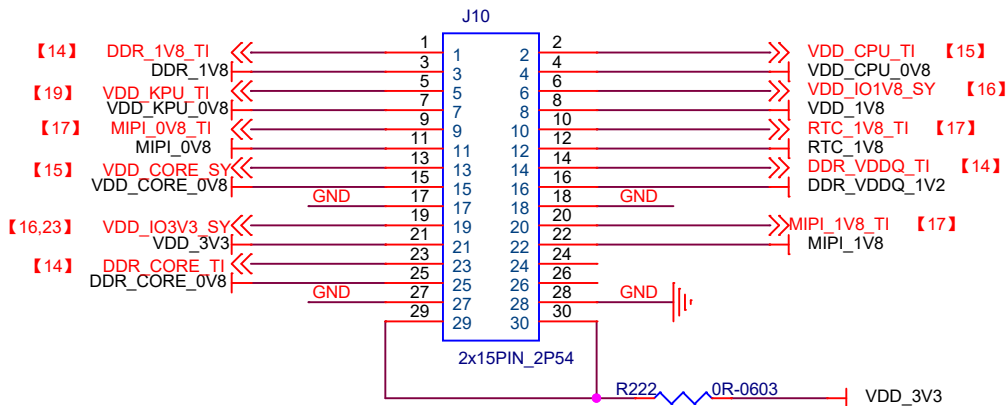
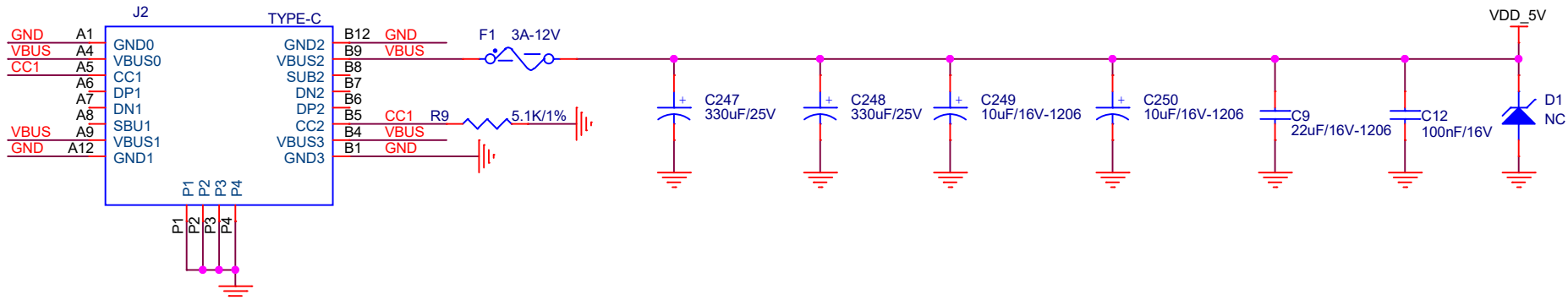

### Current Monitoring EXT to K210

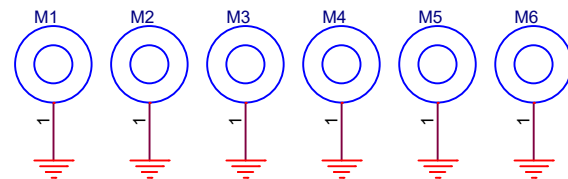
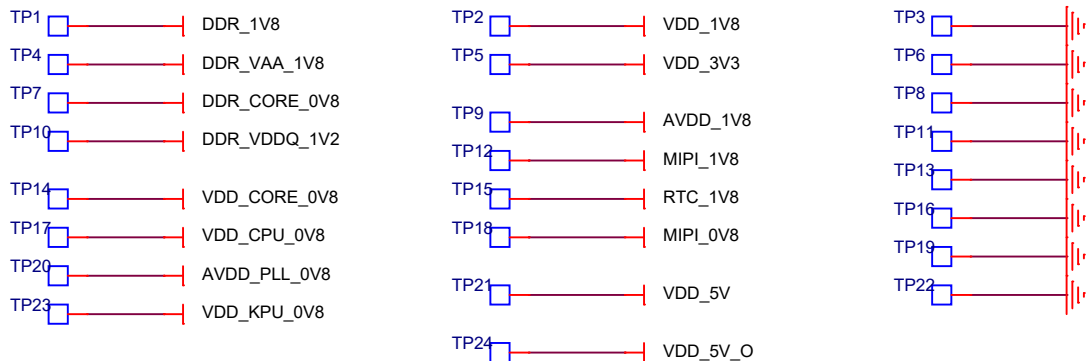

<Core Design>



Title: K230 USIP EVB

Designer: ZYF	Revision: V1.1	Size: A4
---------------	----------------	----------

Date: Monday, June 05, 2023	Sheet 23 of 23
-----------------------------	----------------