

Title		
Size	Number	Revision
A3		
Date:	Sheet	Of
File:	Drawn By:	

HDMI

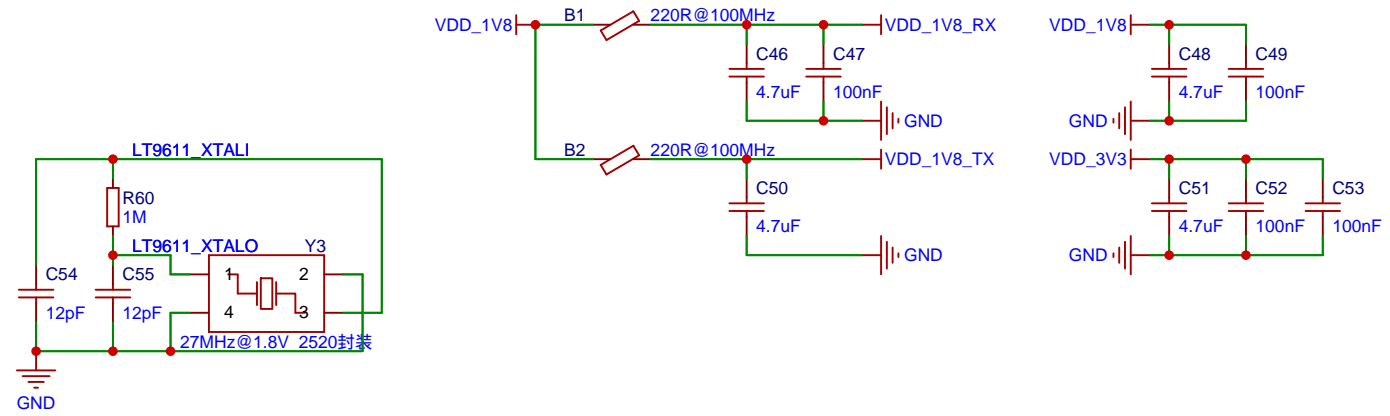
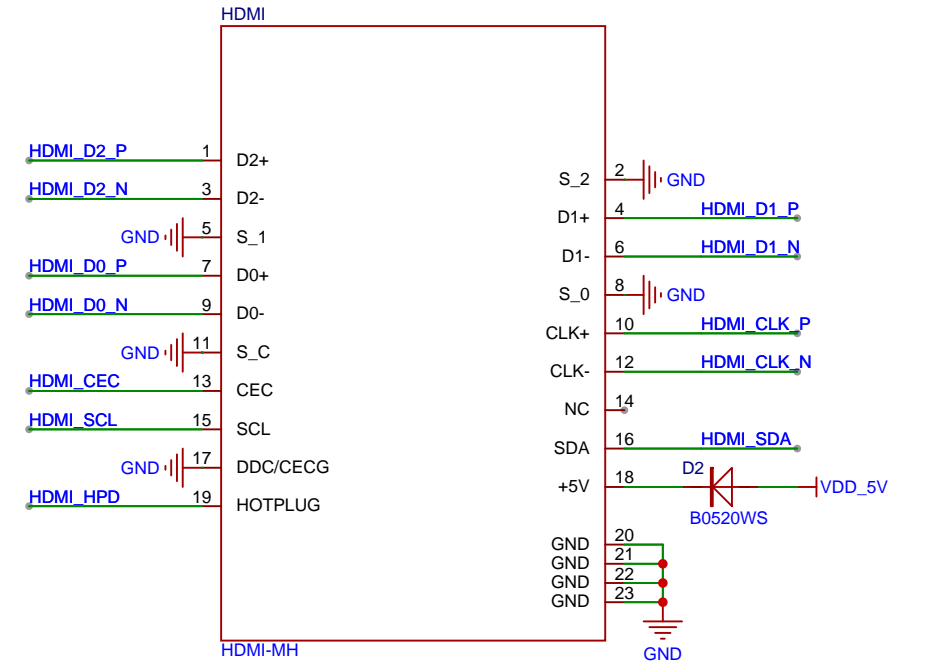
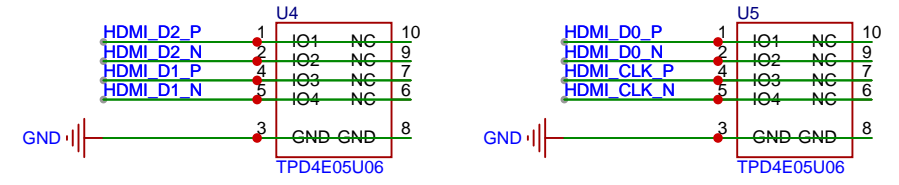
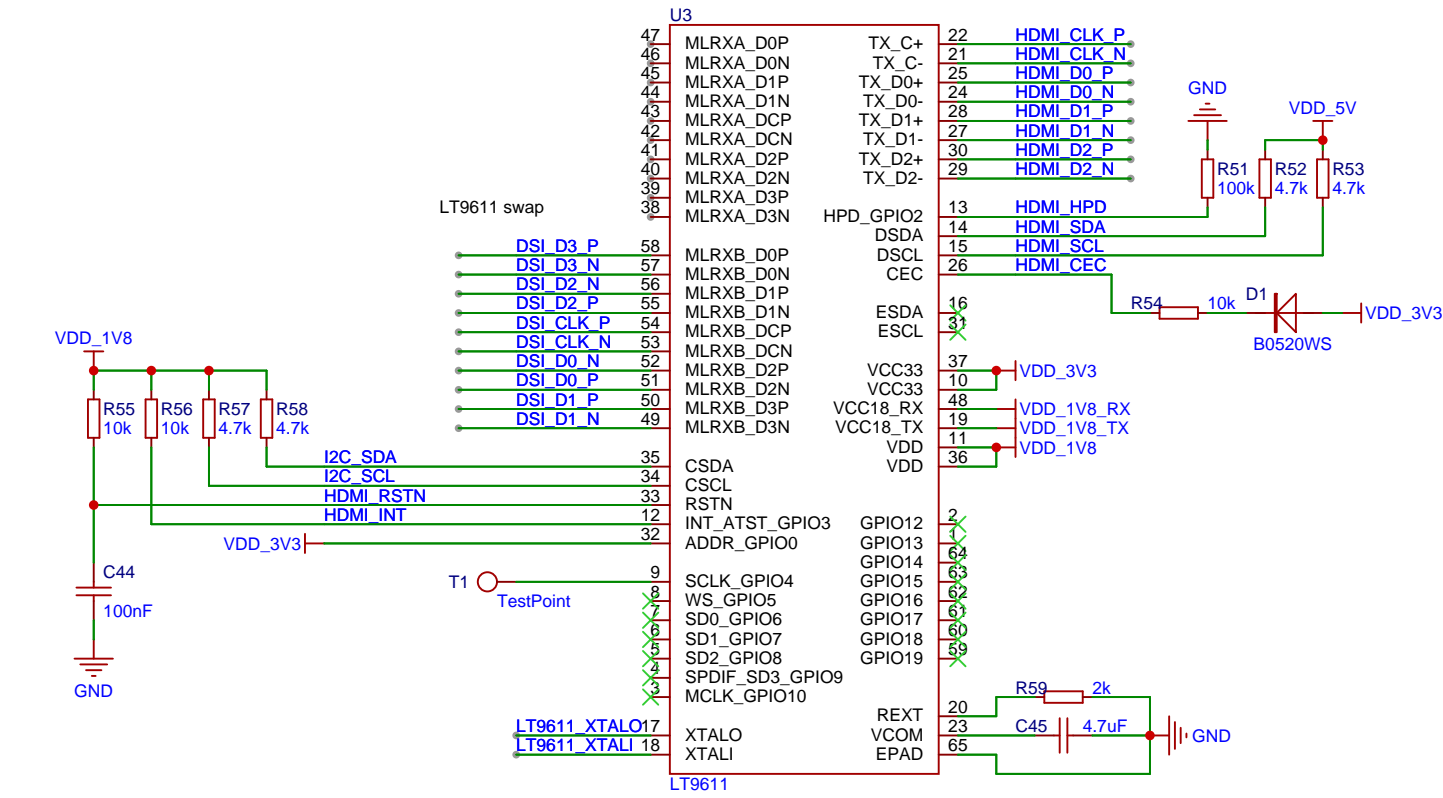

Title		
Size	Number	Revision
A3		
Date:	Sheet	Of
File:	Drawn By:	

Power-K230

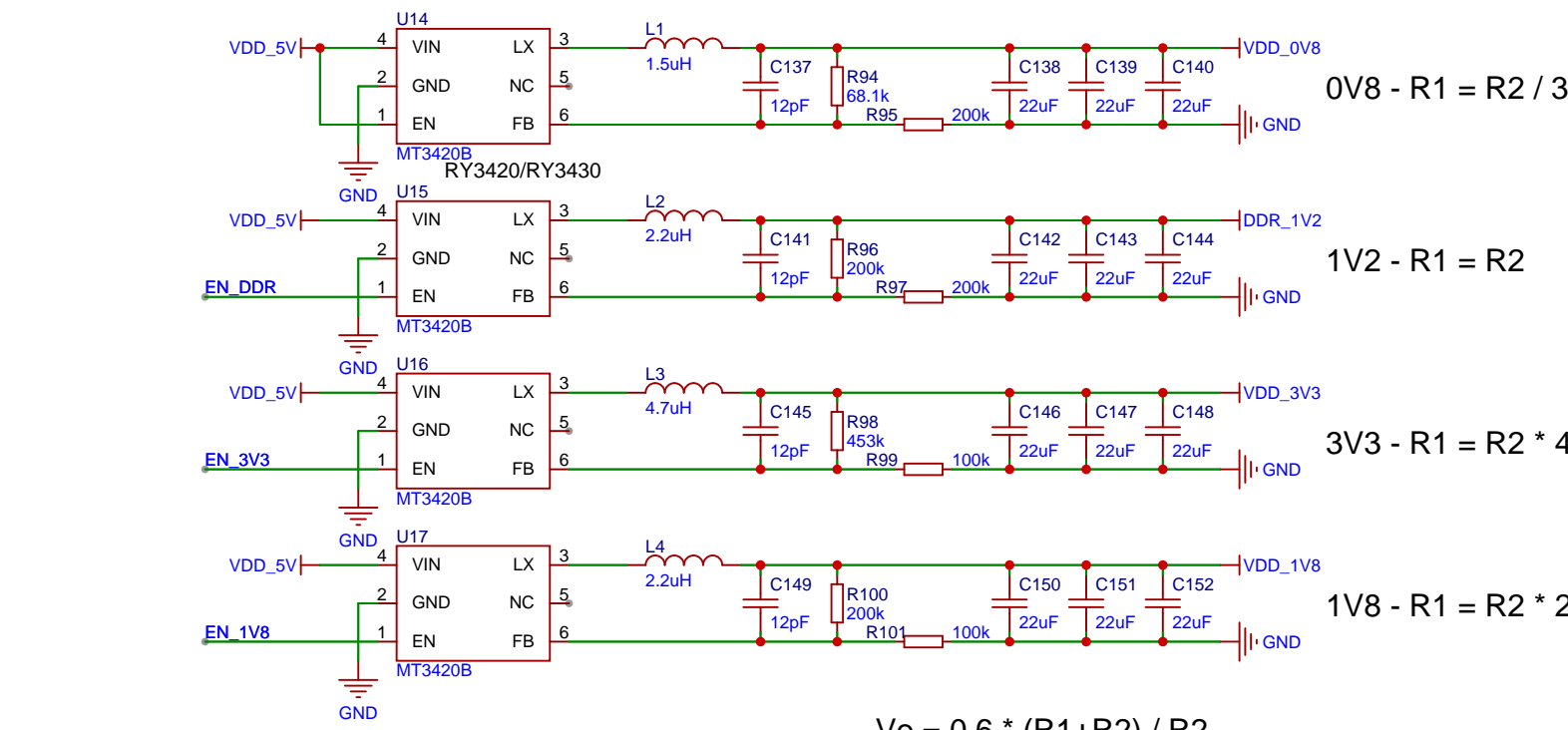
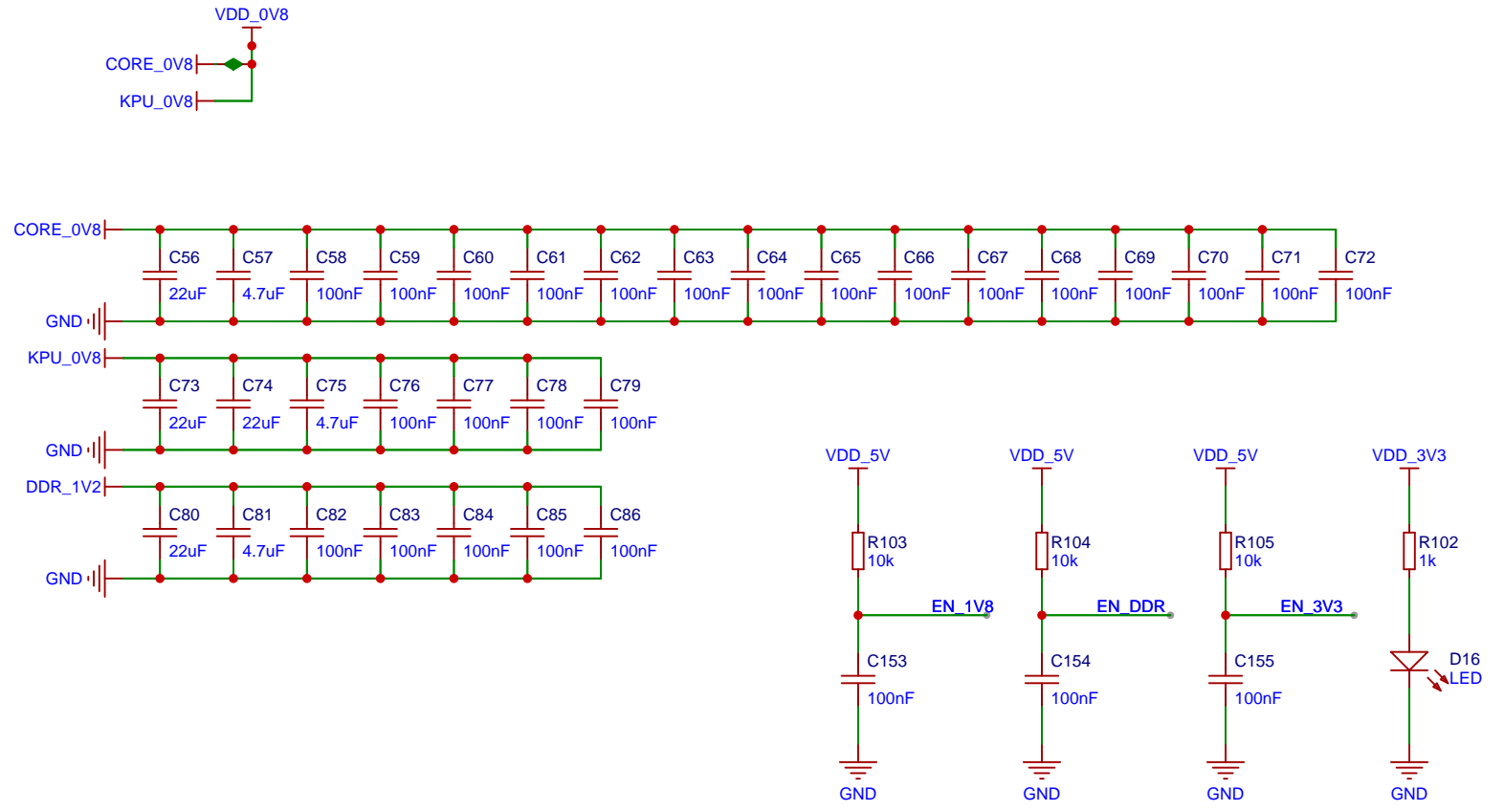
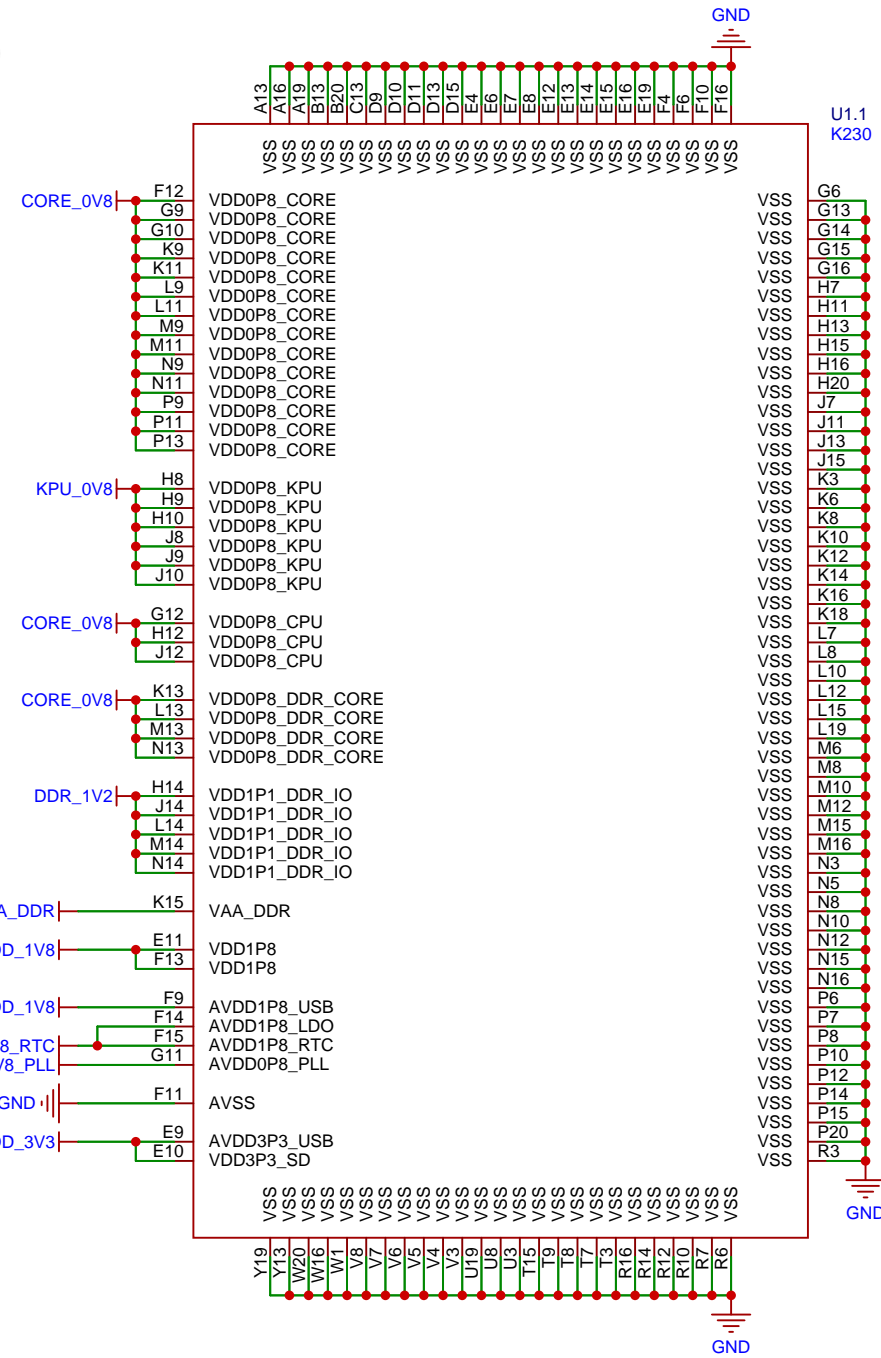

$V_o = 0.6 * (R1+R2) / R2$
 $R1 = (V_o / 0.6 - 1) * R2$
 $R2 = 0.6 * R1 / (V_o - 0.6)$
 $R2 \leq 200k$

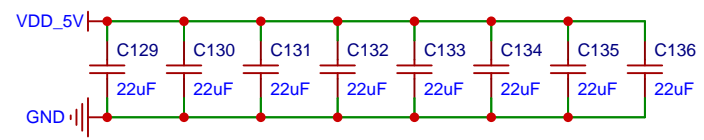
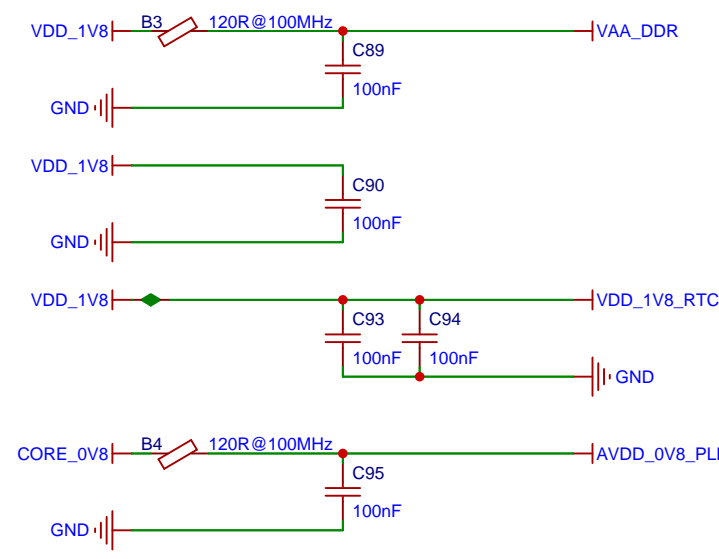
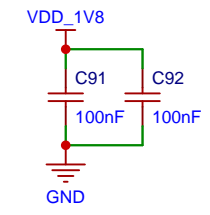
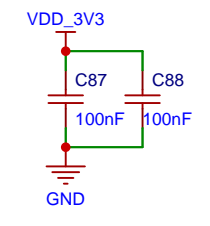

Title		
Size	Number	Revision
A3		
Date:	Sheet	Of
File:	Drawn By:	

USB to Ethernet

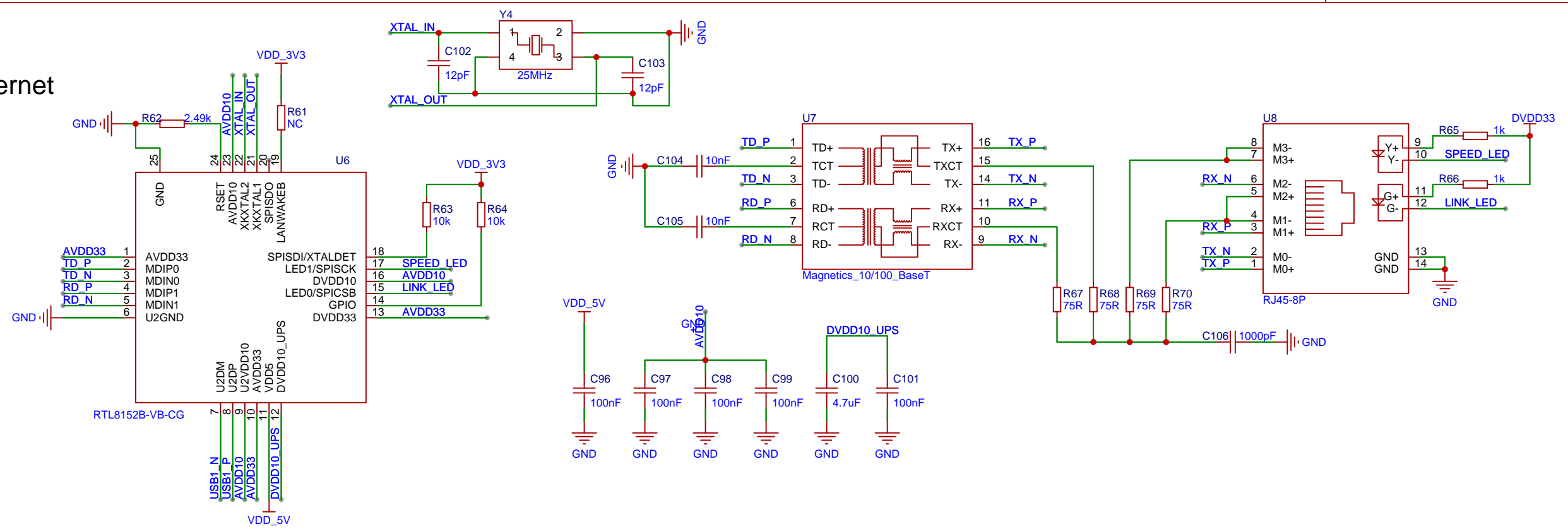

WIFI/BT

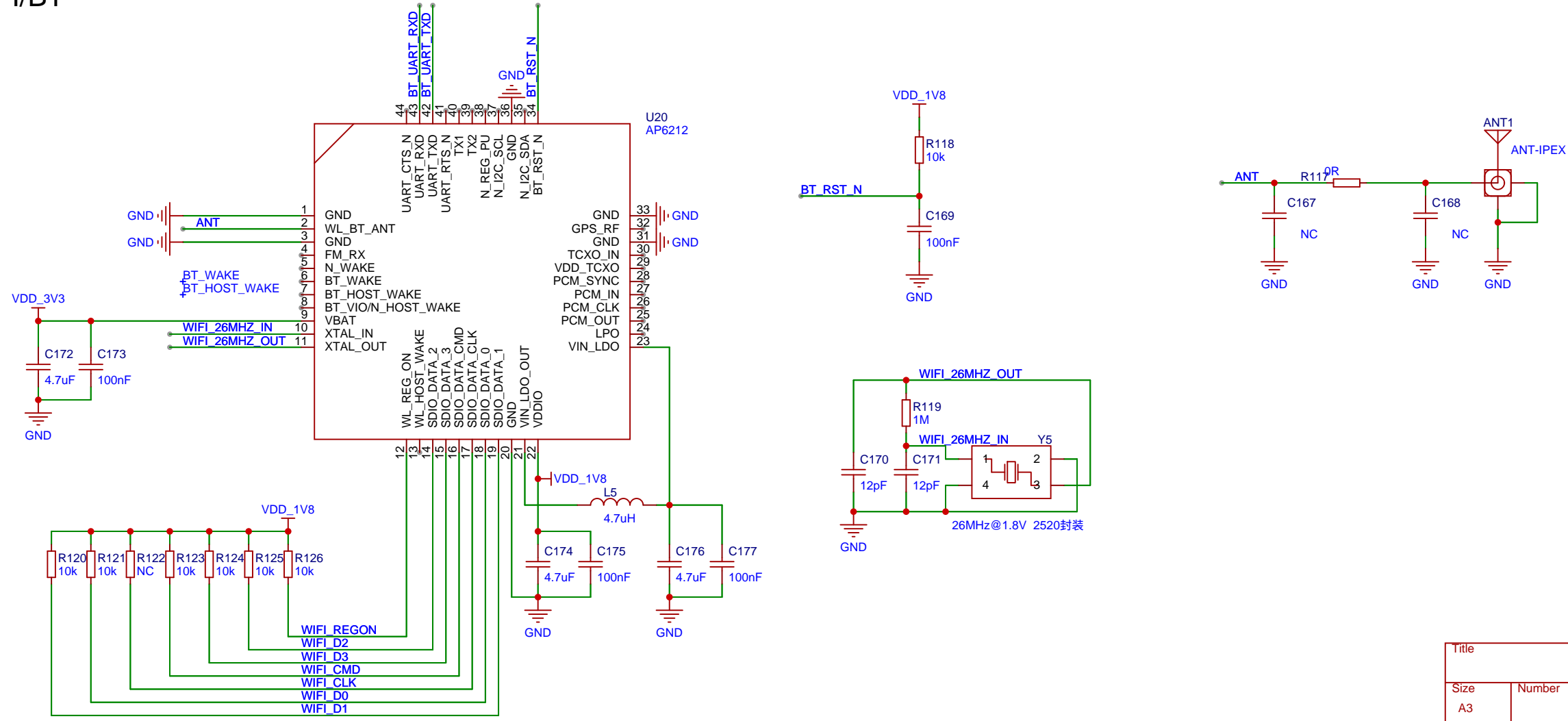

Title		
Size	Number	Revision
A3		
Date:	Sheet Of	
File:	Drawn By:	

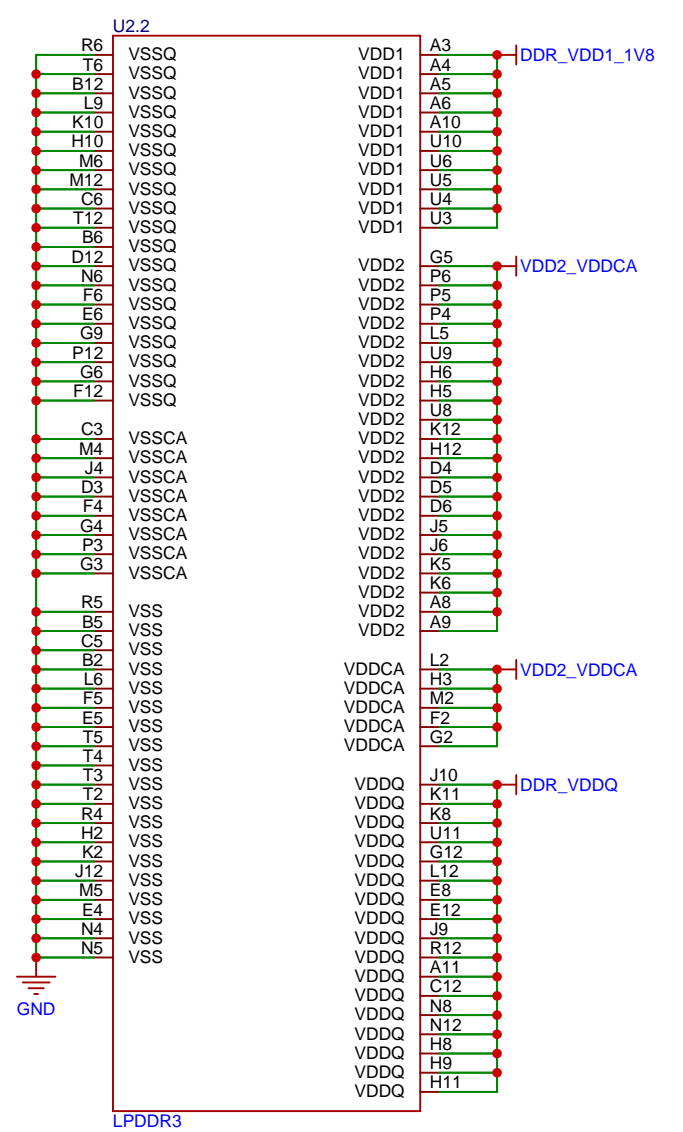
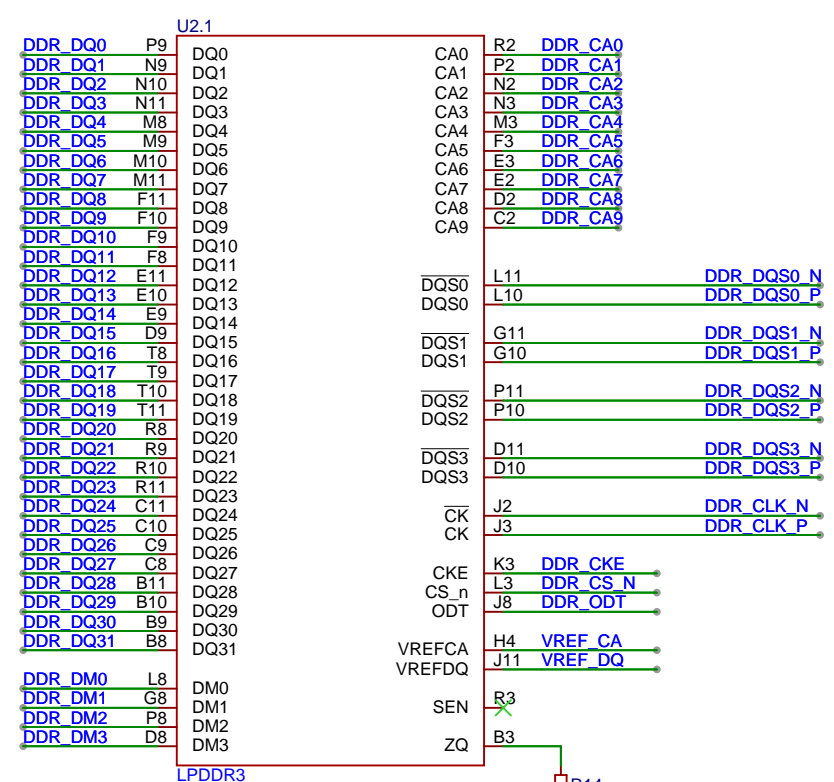
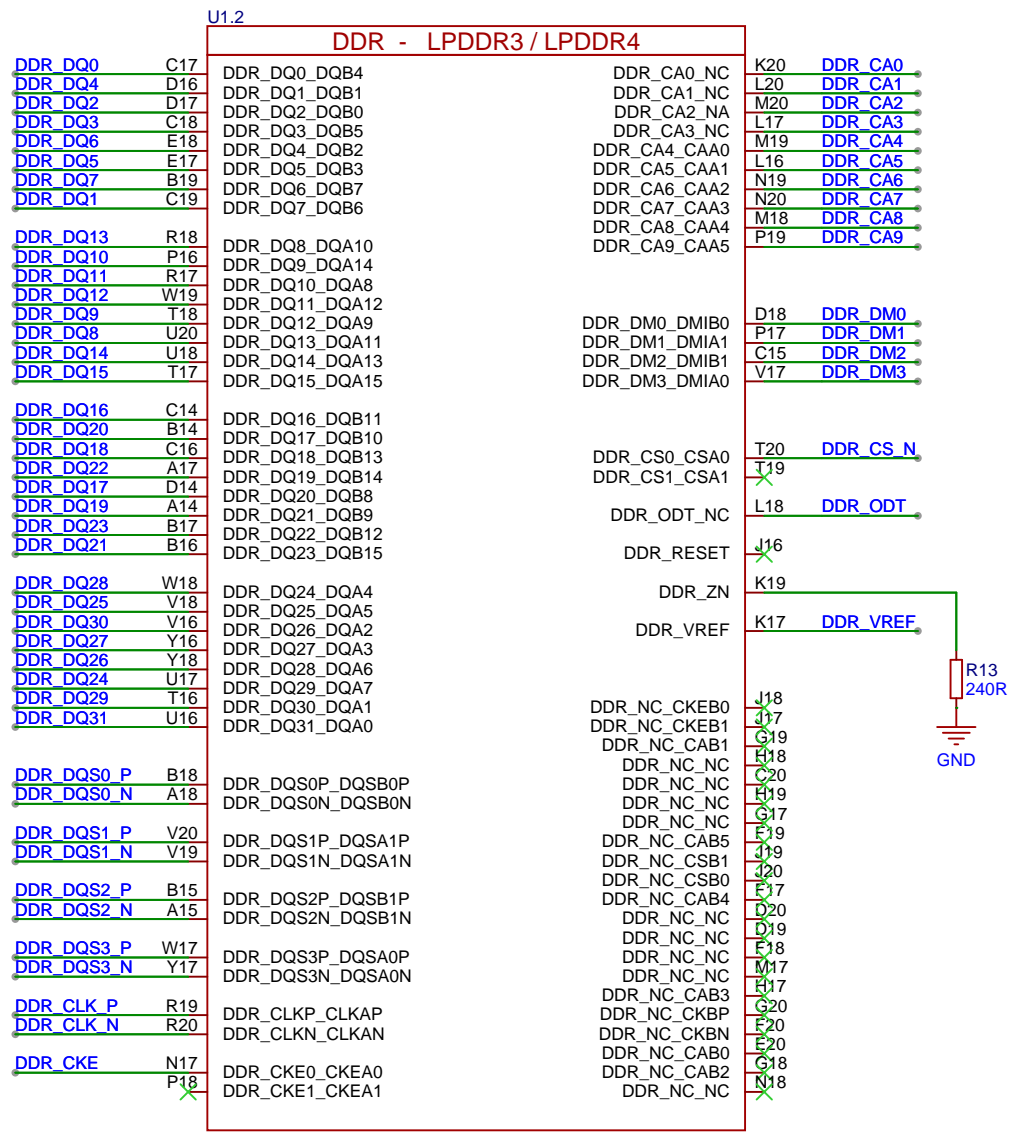

VDD1=1.8V, I_{max} < 50mA
VDD2=1.2V, I_{max} < 50mA
VDDQ=1.2V,
VDDCA=1.2V,

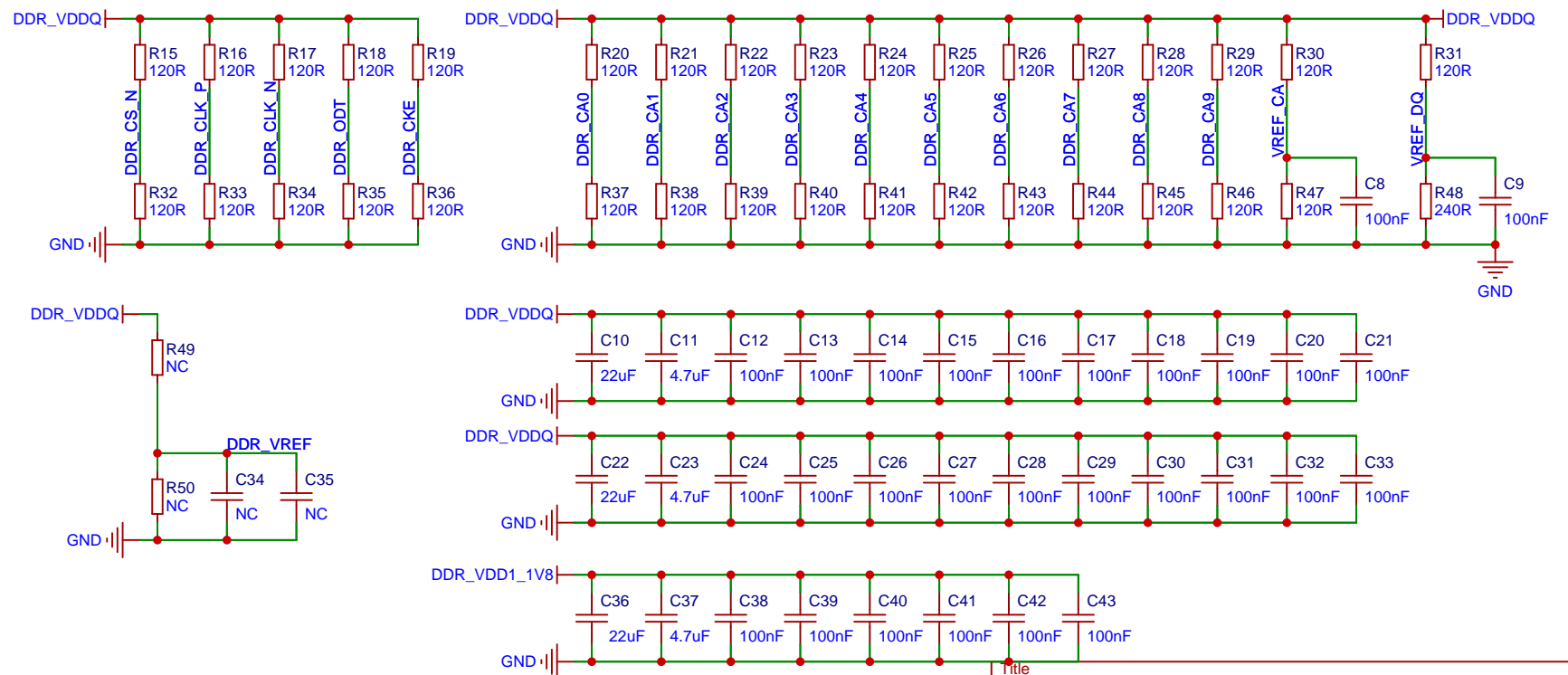

Title		
Size	Number	Revision
A3		
Date:	Sheet	Of
File:	Drawn By:	

Power Supply

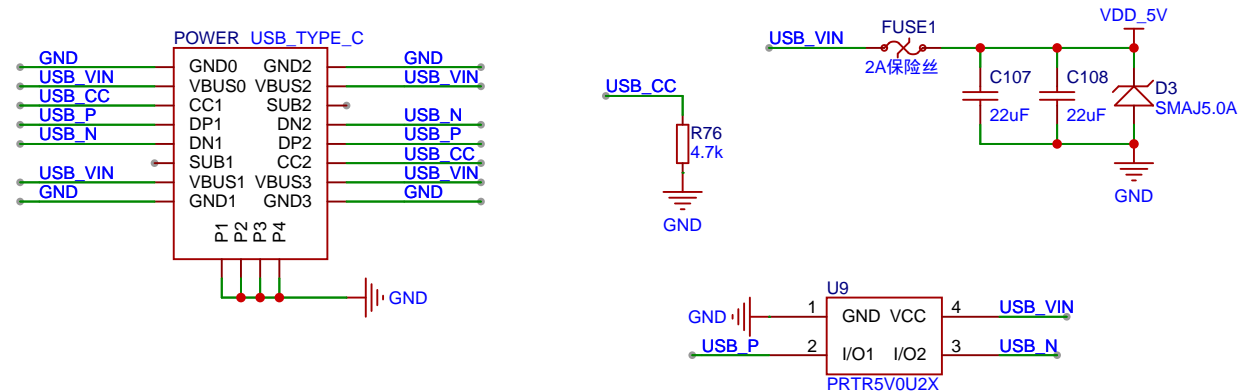

Debug

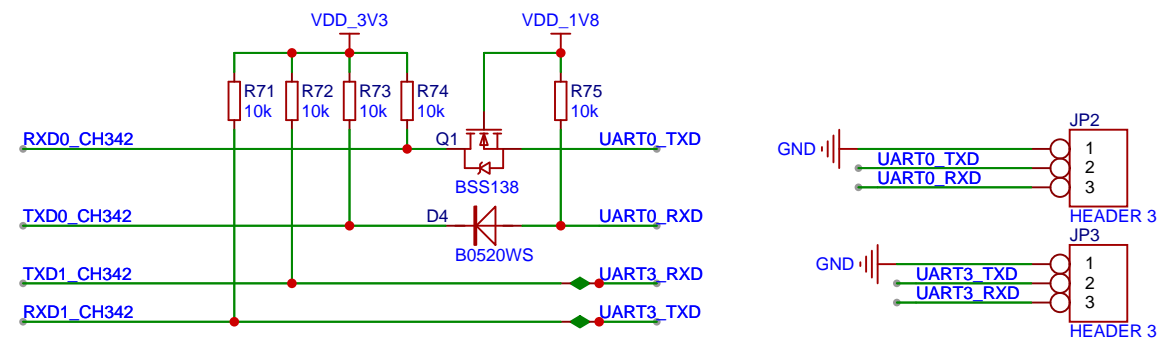

TF CARD

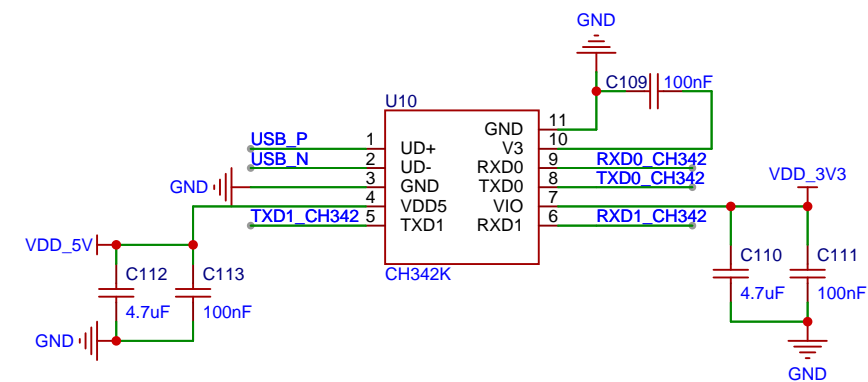
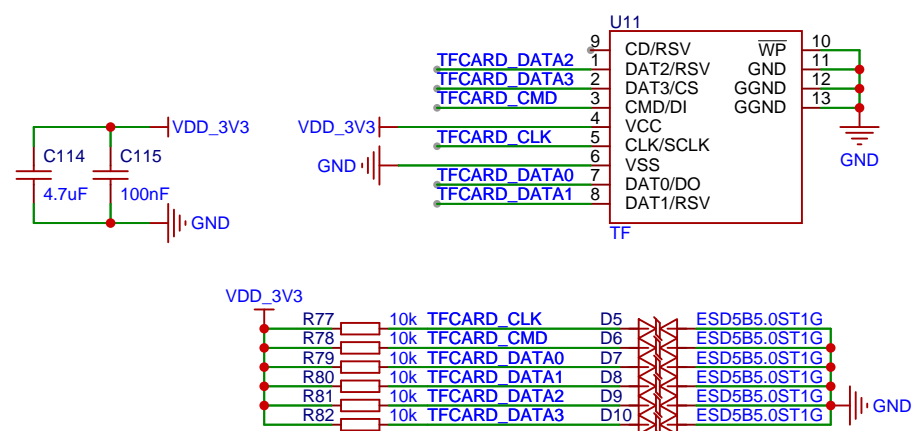

USB

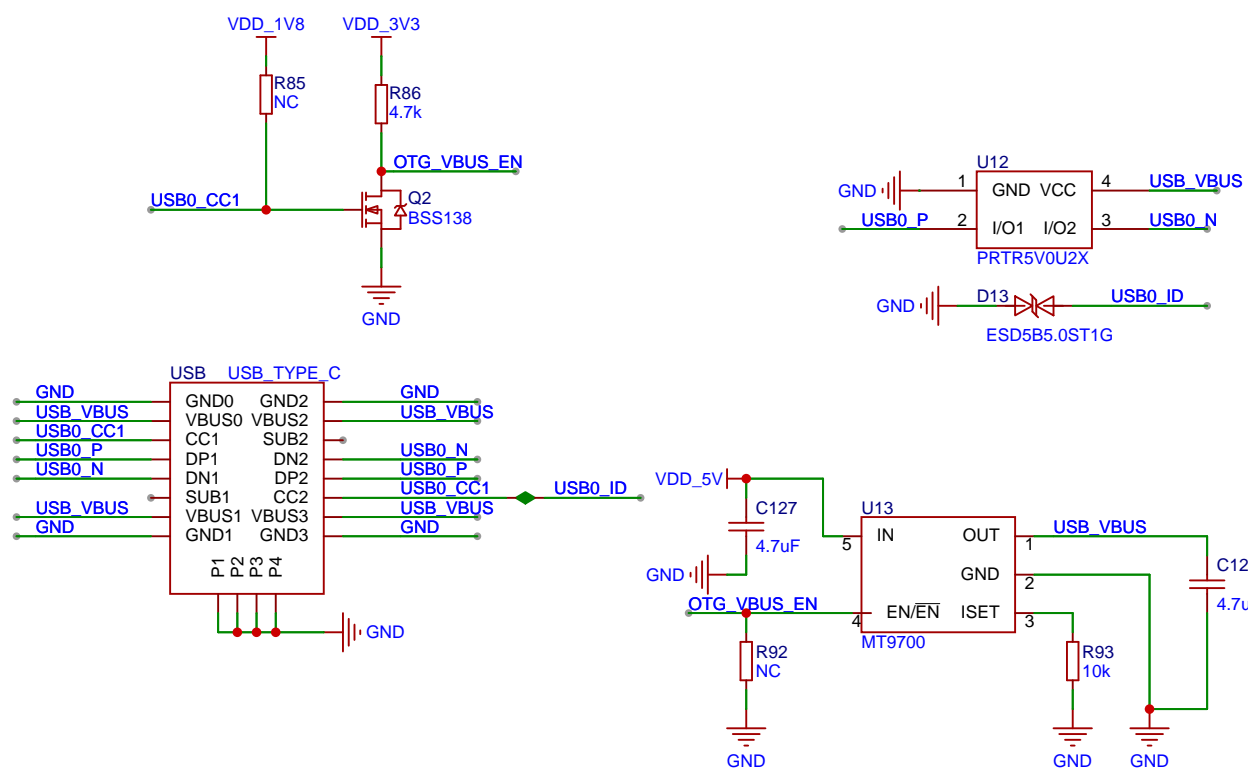

KEY

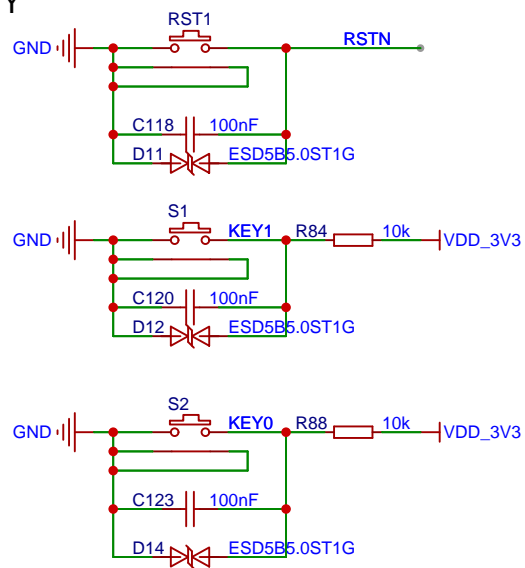

Audio

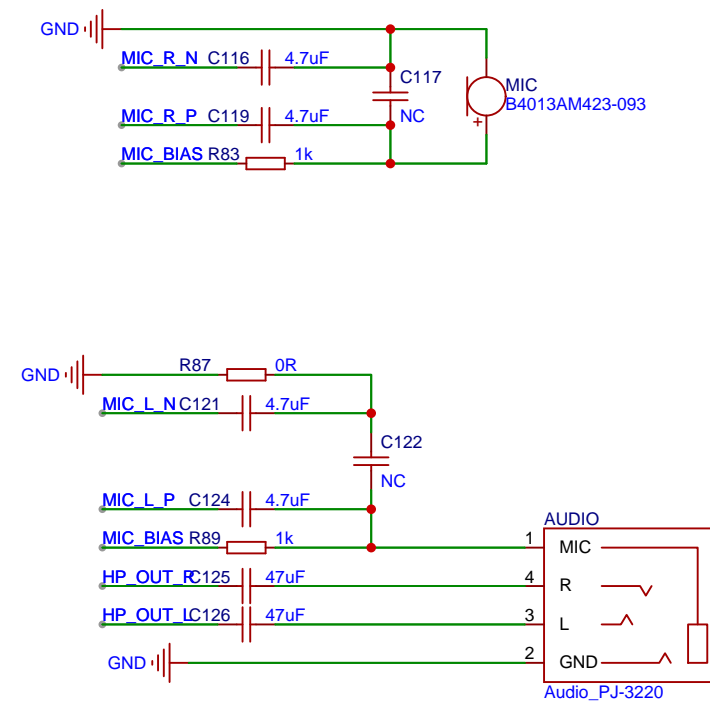

LED

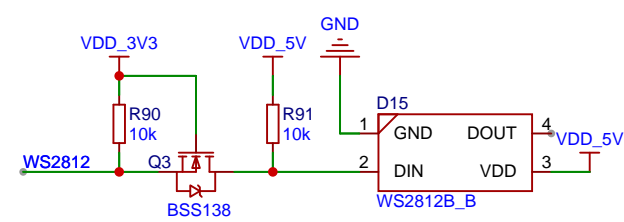

Title		
Size	Number	Revision
A3		
Date:	Sheet	Of
File:	Drawn By:	

MIPI-K230

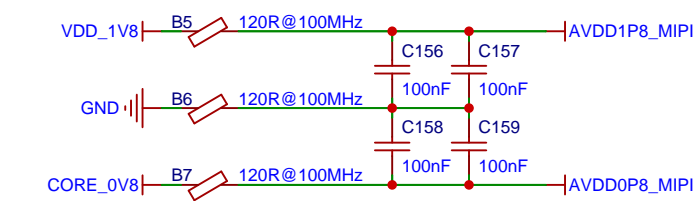
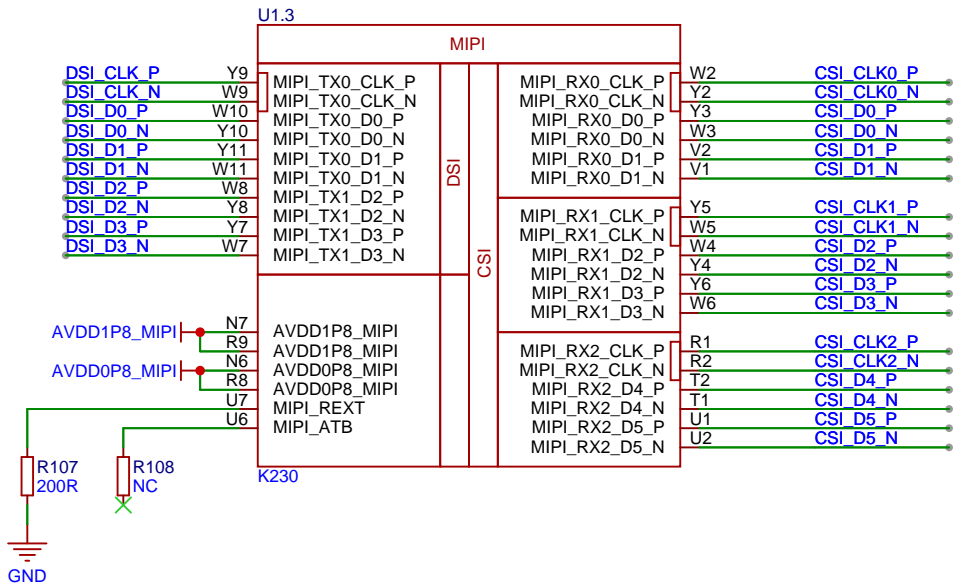

CSI1 + CSI2

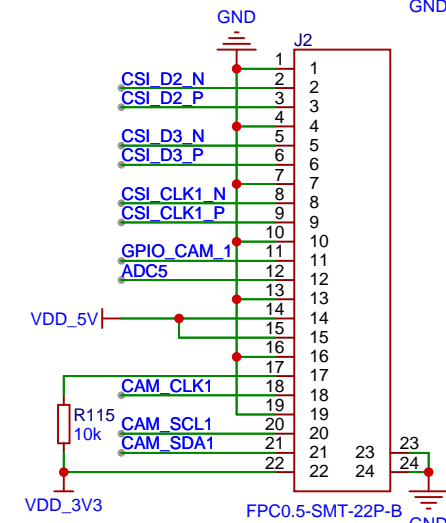
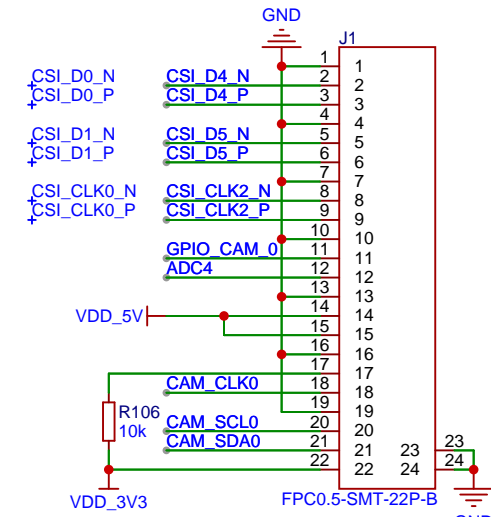
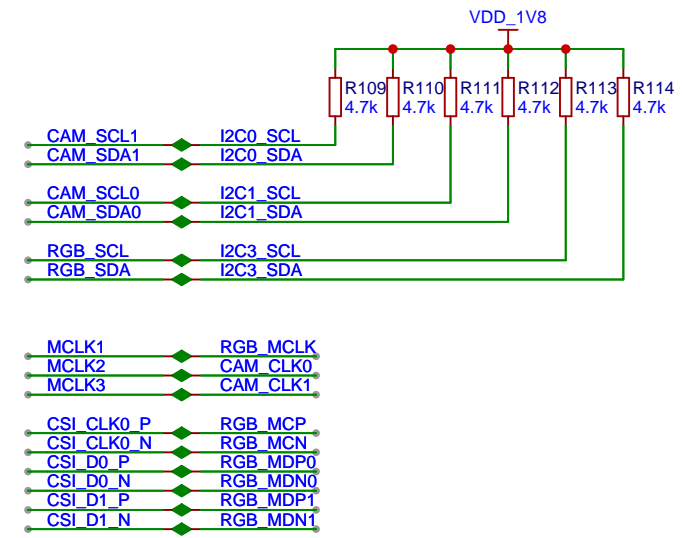

MIPI DSI Interface

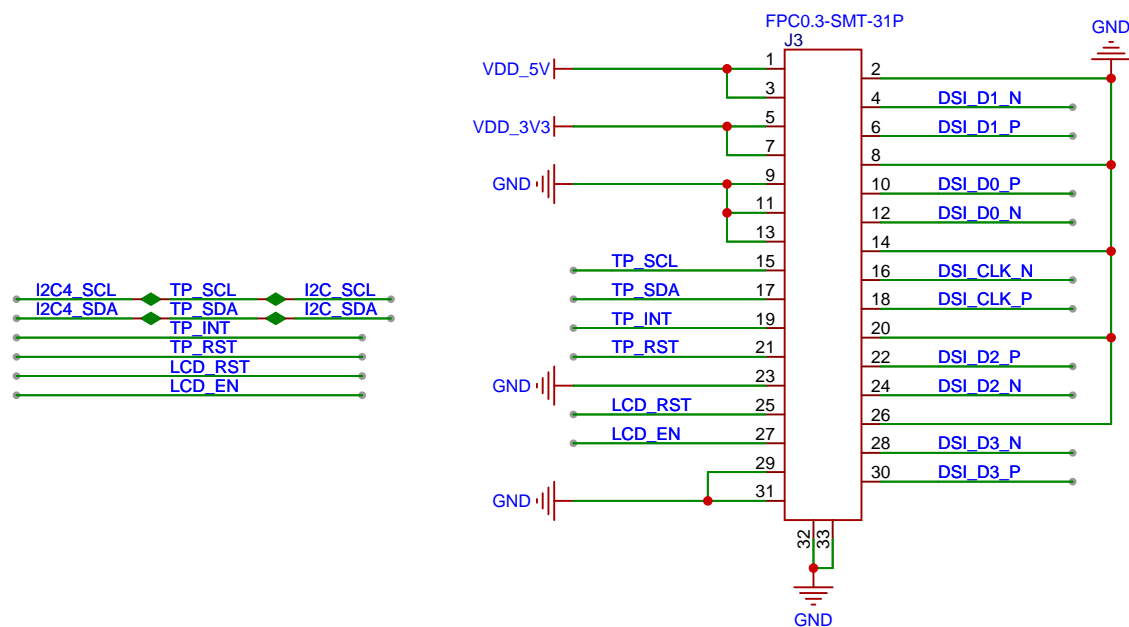

OV5647

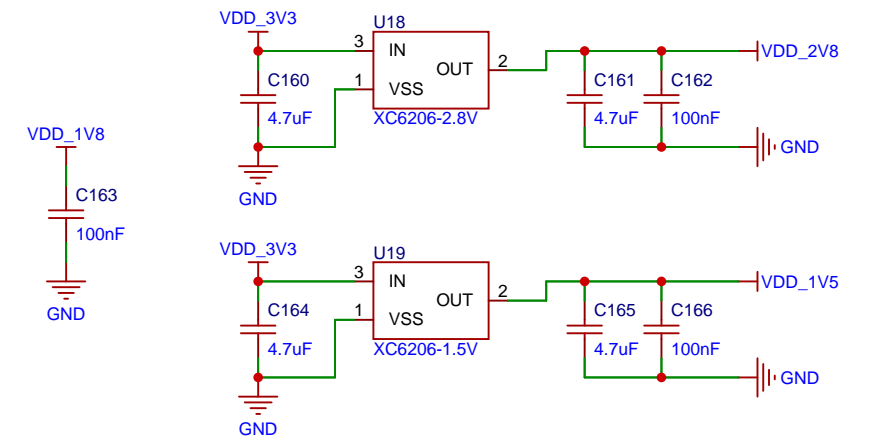
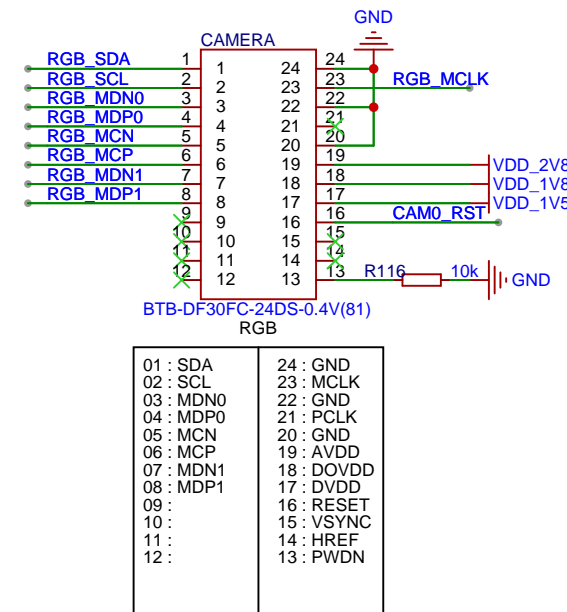

Title		
Size	Number	Revision
A3		
Date:	Sheet	Of
File:	Drawn By:	